

PROJECT MANUAL

PROJECT NAME AND LOCATION:

**Woodland North Apartments
Asphalt Replacement**

Contract Number: TC2400131

TABLE OF CONTENTS

- 02 Invitation to Bid (1 Page)
- 03 Specifications (12 Pages)
- 04 Woodland North Map (1 Page)
- 05 Instructions to Bidders (6 Pages)
- 06 General Conditions (28 Pages)
- 07 Bid Form & Bidder Information (5 Pages) – *Return with Bid*
- 08 Wage Rate Schedule (1 Page)
- 09 Sample Agreement to Pay Prevailing Wages (2 Pages) – *Complete After Award*
- 10 Sample Affidavit of Wages Paid (2 Pages) – *Submit with Final Pay App*
- 11 Sample Contract Form (1 Page)
- 12 Sample Certificate of Insurance (2 Pages)

INVITATION TO BID

Woodland North LLLP will accept bids from qualified general contractors to furnish labor, materials and necessary equipment to perform the following:

SCOPE OF WORK: Work includes, but is not limited to, 2-inch grinding, asphalt paving, extruded concrete curbs, poured in place curbs and gutters, speed bumps, wheel stops and painted striping at locations indicated on the plans and marked at the properties, and other tasks as described in the bid documents.

PROJECT MANUAL DISTRIBUTION:

Address: Woodland North LLLP, 600 Andover Park, Seattle, WA 98188
Distribution: * **Documents are available for download on KCHA's website at <http://www.kcha.org/business/construction/open/>**

PRE-BID CONFERENCE:

Date and Time: May 7, 2024 at 9:25 A.M.
Jobsite Address: Woodland North Apartments, 3611 NE 155th St., Lake Forest Park, WA 98155.
In Addition: Contractors are strongly encouraged to attend the Pre-Bid Conference. Failure to attend the Conference will not relieve the Contractor of any responsibility for information provided at that time. Bidders must have a current certificate of registration as a contractor for the last three years under the same name.
For Questions: Questions pertaining to the bid are to be sent via email to MichelleJ@kcha.org no later than seven (7) calendar days prior to bid due date. All responses shall be in the form of Addenda.

Posting: Addenda will be posted on KCHA's website.

BIDS ARE DUE:

Time: **2:00 P.M.**
Date: **May 23, 2024**
Address: King County Housing Authority
600 Andover Park West, Seattle, WA 98188
Submittal Process: * Sealed Envelope marked as "**Bid Documents:** Woodland North Apartments Asphalt. ATTN: Michelle Jackson (Mailing/Shipping Package must also be marked with this information).
Process: All Bids must be received by King County Housing Authority no later than the above due date and time. No Bids will be accepted after that date and time.
** No Fax or Email Bids will be accepted.

BID GUARANTEE: Not Required.

PERFORMANCE AND PAYMENT BONDS: As a condition of award Performance and Payment bonds for 100% of the Contract Award Amount shall be furnished for the Work. On contracts of one hundred fifty thousand dollars (\$150,000.00) or less, at Contractors option the requirement may be waived in lieu of an additional 5% (total 10%) retainage.

Woodland North LLLP is an Equal Employment Opportunity Employer and strongly encourages minority-owned and women-owned businesses, socially and economically disadvantaged businesses, and small businesses to submit bids or to participate as subcontractors and suppliers.

Woodland North LLLP reserves the right to reject any or all bids or to waive any informality in the bidding. No bid shall be withdrawn for a period of 60 calendar days subsequent to the opening of the bids without the written consent of Woodland North LLLP.

CONTACT PERSON: Michelle Jackson at MichelleJ@kcha.org

SPECIFICATIONS

**Asphalt Replacement
Woodland North**

Contract Number: TC2400131
Page 1 of 12

SECTION 01100 - SUMMARY

PART 1 - GENERAL

1.1 SUMMARY

- A. Project Identification: Asphalt Replacement at Woodland North Apartments
 - 1. Project Location: Woodland North Apartments, 3611 NE 155th Street, Lake Forest Park, WA 98155 (See attached property map for details.)
- B. Work includes 2-inch grinding, asphalt paving, extruded concrete curbs, poured in place curbs and gutters, speed bumps, wheel stops and painted striping at locations indicated on the plans and marked at the properties. All painted striping to match existing.
- C. Properties with more than 15,000 square feet of asphalt replacement will require additional mobilizations as noted on property maps attached.
- D. All mobilizations to include temporary sanitation (portable toilets).
- E. Traffic control is required at all properties.
- F. Advance notification is required for each property, with a minimum of 48 hours notification.
- G. Normal work hours are 8:00 AM to 6:00 PM. Additional work hours may be allowed, at the discretion of KCHA, if contractor notifies KCHA a minimum of 48 hours in advance and if approved by KCHA. Without prior approval all work must cease by 6:00 PM including clean up and equipment movement.

1.2 WORK SEQUENCE

- A. The Work shall be completed in 30 calendar days from the date of Notice to Proceed and shall be completed on consecutive days at each property.
 - 1. Contractor shall be entitled to an equitable adjustment in the Contract Time for changes in the time of performance directly attributable to severe weather conditions. For additional days to be considered the Contractor shall notify the Owner no later than 8:00 a.m. on each day of a severe weather condition.
- B. Contractor will submit written schedule outlining dates and duration of job including:
 - 1. Construction start date
 - 2. Schedule for work at each property
 - 3. Anticipated final completion date
- C. Minimum number of mobilizations for each property is listed in Section 02741, 3.10 - Quantities.

SPECIFICATIONS

**Asphalt Replacement
Woodland North**

Contract Number: TC2400131
Page 2 of 12

1.3 LIQUIDATED DAMAGES

- A. Liquidated damages will be assessed for each calendar day that the Contractor exceeds the time for completion in the amount of \$500.

1.4 USE OF THE PREMISES

- A. Use of Site: Limit use of premises to work areas. Do not disturb portions of site beyond areas in which the Work is indicated.
 - 1. Owner Occupancy: Allow for resident occupancy of site. Owner will occupy site and existing building during entire construction period. Cooperate with Owner during construction operations to minimize conflicts and facilitate resident usage.
 - 2. Driveways and Entrances: Keep driveways and entrances serving premises clear and available to residents and emergency vehicles at all times. Do not use these areas for parking or storage of materials.
 - 3. Use of Existing Building: Maintain existing building in a weathertight condition throughout construction period. Repair damage caused by construction operations. Protect property, the buildings and occupants during construction period.

1.5 PERMITS

- A. Contractor is responsible for obtaining and paying for all permits, fees, and other costs, and for coordination of all required inspections.

1.6 UNIT PRICES

- A. Unit prices are an amount, stated by bidders on the Form of Proposal, as a price per unit of measurement for materials or services added to or deducted from the Contract Sum if the estimated quantities of Work required by the Contract Documents are increased or decreased. Unit prices will be used to determine the adjustment to the Contract Sum.
- B. Unit prices include necessary material, plus cost for delivery, preparations, excavation, compaction, demolition, installation, disposal, insurance, and direct and indirect costs associated with the Unit Price item.
- C. The Owner reserves the right to accept or reject any Unit Prices during the term of the Contract. If the Owner rejects a Unit Price, then the Contractor shall be required to submit to the Owner a breakdown of costs for the activity covered by the Unit Price. The Owner then shall make a determination as to what costs are allowable.
- D. Unit Price List
 - 1. Unit Price No. 1 – Asphalt Replacement
 - a. Unit of measure – Square foot.
 - b. The base bid includes replacement of an estimate of 7,825 square feet of asphalt as indicated in the plans, specifications and as marked at the properties.

SPECIFICATIONS

**Asphalt Replacement
Woodland North**

**Contract Number: TC2400131
Page 3 of 12**

- c. If, on inspection, the quantity required is reduced by the Owner, the Unit Price will be used as a deductive.
 - d. In the event that further asphalt is required the Unit Price will be used as an additive.
- 2. Unit Price No. 2 – Extruded Curb
 - a. Unit of measure – Linear foot.
 - b. The base bid includes replacement of a combined estimate of 30 linear feet of extruded curb as indicated in the plans, specifications and as marked at the properties.
 - c. If, on inspection, the quantity required is reduced by the Owner, the Unit Price will be used as a deductive.
 - d. In the event that further asphalt is required the Unit Price will be used as an additive.
- 3. Unit Price No. 3 – Curb and Gutter
 - a. Unit of measure – Linear foot.
 - b. The base bid includes replacement of a combined estimate of 160 linear feet of curb and gutter as indicated in the plans, specifications and as marked at the properties.
 - c. If, on inspection, the quantity required is reduced by the Owner, the Unit Price will be used as a deductive.
 - d. In the event that further curb and gutter is required the Unit Price will be used as an additive.
- 4. Unit Price No. 4 – Speed Bumps
 - a. Unit of measure – Each.
 - b. The base bid includes replacement of a combined estimate of 0 speed bumps as indicated in the plans, specifications and as marked at the properties.
 - c. If, on inspection, the quantity required is reduced by the Owner, the Unit Price will be used as a deductive.
 - d. In the event that additional speed bumps are required the Unit Price will be used as an additive.
- 5. Unit Price No. 5 – Wheel Stops
 - a. Unit of measure – Each.
 - b. The base bid includes replacement of a combined estimate of 0 wheel stops as indicated in the plans, specifications and as marked at the properties.
 - c. If, on inspection, the quantity required is reduced by the Owner, the Unit Price will be used as a deductive.
 - d. In the event that additional wheel stops are required the Unit Price will be used as an additive.

1.7 HAZARDOUS MATERIALS

- A. Hazardous Materials: It is not expected that hazardous materials will be encountered in the Work.

SPECIFICATIONS

**Asphalt Replacement
Woodland North**

Contract Number: TC2400131
Page 4 of 12

1. If materials suspected of containing hazardous materials are encountered, do not disturb and immediately notify Owner. Hazardous materials will be removed by Owner under a separate contract.

1.8 PAYMENT PROCEDURES

- A. Waivers of Lien: With each Application for Payment, submit conditional waivers lien from every entity that is lawfully entitled to file a lien arising out of the Contract and related to the Work covered by the payment.
 1. Submit partial waivers on each item for amount requested, before deduction for retainage, on each item.
 2. When an application shows completion of an item, submit final or full waivers.
 3. Owner reserves the right to designate which entities involved in the Work must submit waivers.
 - a. Submit final Application for Payment with or preceded by final waivers from every entity involved with performance of the Work covered by the application who is lawfully entitled to a lien.
- B. Final Payment Application: Submit final Application for Payment with releases and close out supporting documentation.

1.9 PROJECT MEETINGS

- A. Preconstruction Conference: Schedule a preconstruction conference before starting construction, at a time convenient to Owner, but no later than seven days after execution of the Agreement.

1.10 SUBMITTALS

- A. Provide product data for each element of construction and type of product or equipment for approval by Owner.

1.11 TEMPORARY FACILITIES

- A. Sanitary Facilities: Provide temporary toilets, wash facilities, and drinking-water fixtures. Comply with regulations and health codes for type, number, location, operation, and maintenance of fixtures and facilities.
- B. Use of Owner's existing electric power service is not permitted.

1.12 EXECUTION REQUIREMENTS

- A. General: Clean Project site and work areas daily, including common areas. Enforce requirements strictly. Dispose of materials lawfully.

SPECIFICATIONS

**Asphalt Replacement
Woodland North**

**Contract Number: TC2400131
Page 5 of 12**

1.13 PROJECT CONDITIONS

- A. Perform utility-locator service for area where Project is located before excavating. Contractor shall be responsible for all damage and for all costs associated with tenant costs that result from damage.

1.14 CUTTING AND PATCHING

A. Quality Assurance

- 1. Structural Elements: Do not cut and patch structural elements in a manner that could change their load-carrying capacity or load-deflection ratio.
- 2. Visual Requirements: Do not cut and patch construction in a manner that results in visual evidence of cutting and patching. Do not cut and patch construction exposed on the exterior or in occupied spaces in a manner that would, in Owner's opinion, reduce the building's aesthetic qualities. Remove and replace construction that has been cut and patched in a visually unsatisfactory manner.

B. Performance

- 1. Cutting: Cut existing construction by sawing, drilling, breaking, chipping, grinding, and similar operations, including excavation, using methods least likely to damage elements retained or adjoining construction. If possible, review proposed procedures with original Installer; comply with original Installer's written recommendations.
- 2. Patching: Patch construction by filling, repairing, refinishing, closing up, and similar operations following performance of other Work. Patch with durable seams that are as invisible as possible. Provide materials and comply with installation requirements specified in other Sections of these Specifications.
 - a. Exposed Finishes: Restore exposed finishes of patched areas and extend finish restoration into retained adjoining construction in a manner that will eliminate evidence of patching and refinishing.

1.15 CLOSEOUT PROCEDURES

- A. General: Provide final cleaning. Conduct cleaning and waste-removal operations to comply with local laws and ordinances and Federal and local environmental and antipollution regulations.
 - 1. Prior to acceptance of the work at each building, clean project site, yard, and grounds, in areas disturbed by construction activities, including landscape development areas, of rubbish, waste material, litter, and other foreign substances.
- B. Prior to final acceptance and final payment, Contractor shall submit a written warranty covering labor and materials for a period of two (2) years from final completion.

PART 2 - PRODUCTS (not used)

PART 3 - EXECUTION (not used)

END OF SECTION 01100

SUMMARY

01100 - 5

SPECIFICATIONS

**Asphalt Replacement
Woodland North**

Contract Number: TC2400131
Page 6 of 12

SECTION 02741 - HOT-MIX ASPHALT PAVING

PART 1 - GENERAL

1.1 SUMMARY

- A. The Contractor shall furnish all labor and material, equipment, services and perform and complete all work required as indicated on plan and marked at the property. Workmanship shall be guaranteed for two (2) years from date of completion.

1.2 QUALITY ASSURANCE

- A. Asphalt-Paving Publication: Comply with AI MS-22, "Construction of Hot Mix Asphalt Pavements," unless more stringent requirements are indicated.

1.3 PROJECT CONDITIONS

- A. Environmental Limitations: Do not apply asphalt materials if subgrade is wet or excessively damp.
- B. Pavement-Marking Paint: Proceed with pavement marking only on clean, dry surfaces and at a minimum ambient or surface temperature of 40 deg F.

PART 2 - PRODUCTS

2.1 AGGREGATES

- A. General: Use materials and gradations that have performed satisfactorily in previous installations.

2.2 ASPHALT MATERIALS

- A. Hot-Mix Asphalt: Dense, hot-laid, hot-mix asphalt plant mixes approved by authorities having jurisdiction and designed according to procedures in AI MS-2, "Mix Design Methods for Asphalt Concrete and Other Hot-Mix Types."
 - 1. Provide mixes with a history of satisfactory performance in geographical area where Project is located.
 - 2. Provide mixes complying with composition, grading, and tolerance requirements in ASTM D 3515.
- B. Solid tack coat of SS-1 asphalt adhesive.

SPECIFICATIONS

**Asphalt Replacement
Woodland North**

Contract Number: TC2400131

Page 7 of 12

- C. Hot poured crack sealing material.

2.3 CURBS

- A. Cement concrete traffic curb and gutter: Air entrained concrete Class 4000 conforming to WSDOT Standard Spec 6-02.

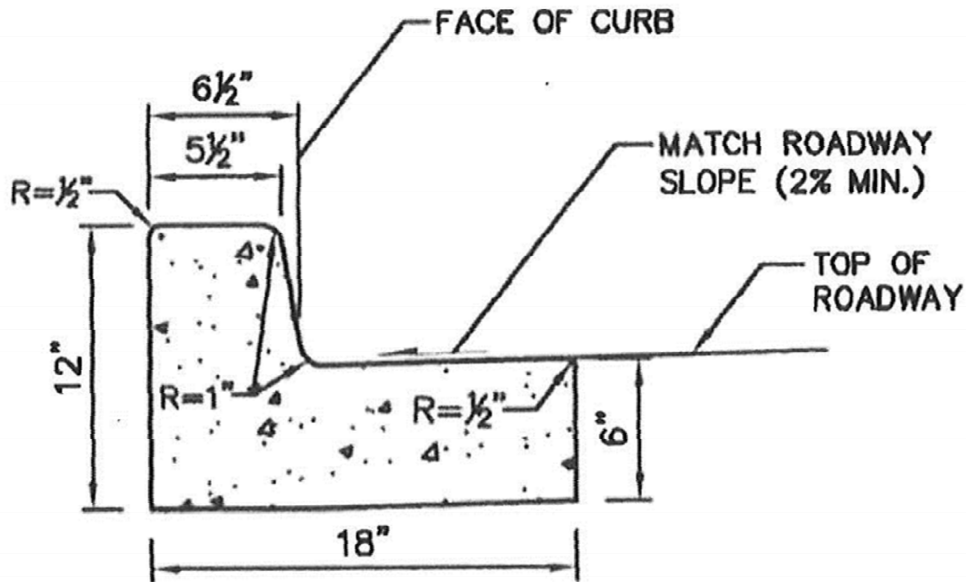

CEMENT CONCRETE
TRAFFIC CURB AND GUTTER

SPECIFICATIONS

**Asphalt Replacement
Woodland North**

Contract Number: TC2400131

Page 8 of 12

B. Cement concrete extruded curb: Match adjacent profile.

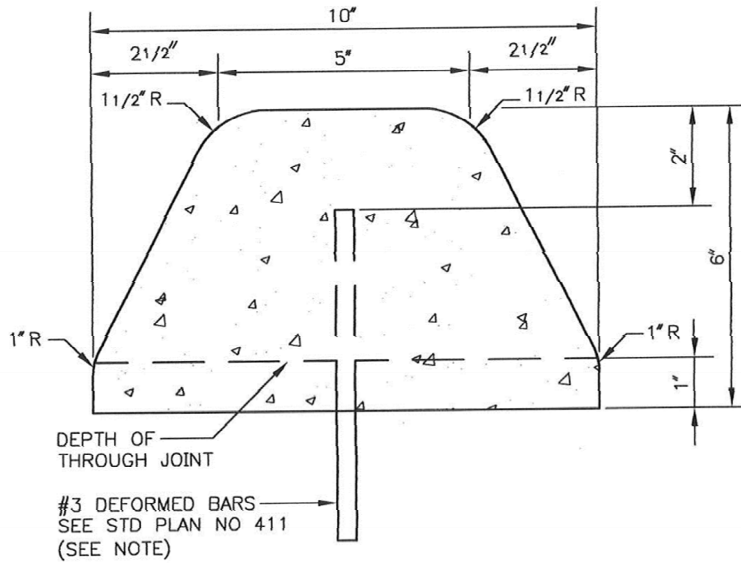

EXTRUDED CEMENT CONCRETE CURB

NOTE:
ALTERNATELY, THE USE OF EPOXY BONDING AGENT,
IN PLACE OF #3 DEFORMED BARS, WILL BE ALLOWED.

SPECIFICATIONS

**Asphalt Replacement
Woodland North**

Contract Number: TC2400131

Page 9 of 12

2.4 WHEEL STOPS

C. Precast Concrete Parking Curb / Bumper

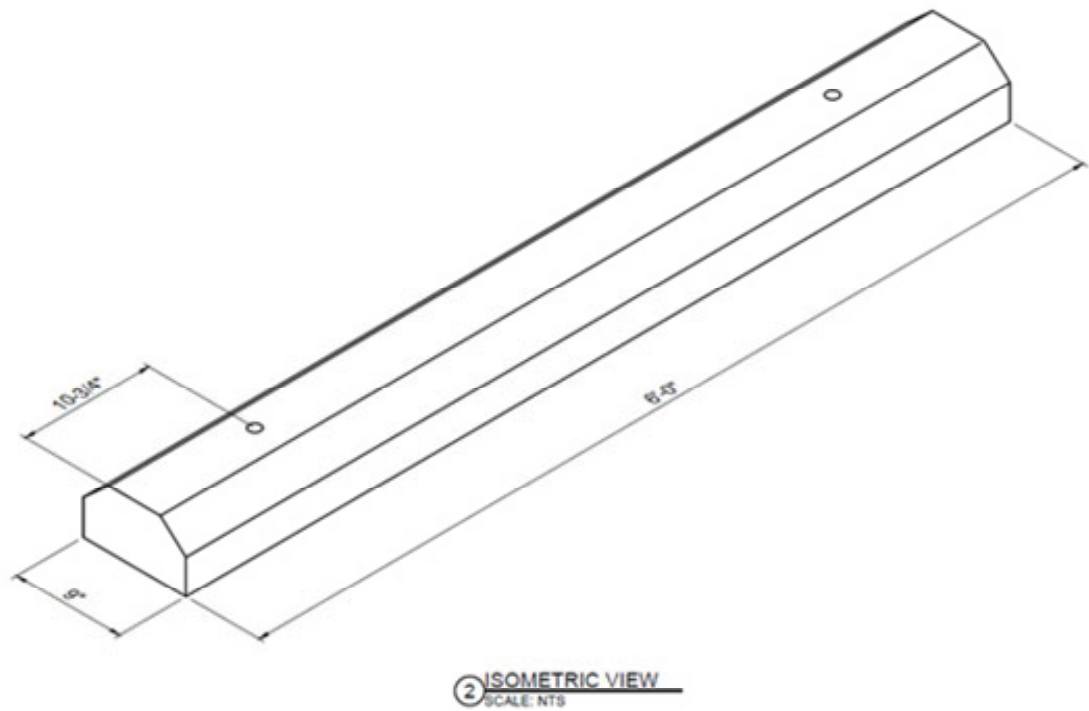
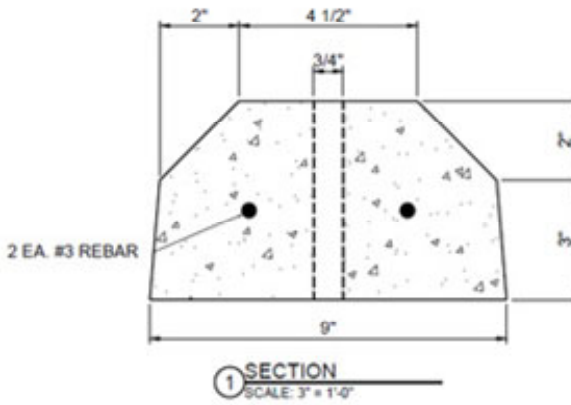

- NOTES:
1. REBAR AMERICAN GRADE 60 SIZE #3.
 2. 4000 PSI CONCRETE 28 DAYS.
 3. WEIGHT 200 POUNDS.

SPECIFICATIONS

**Asphalt Replacement
Woodland North**

Contract Number: TC2400131
Page 10 of 12

2.5 PAVEMENT MARKING

A. Solvent Based Pavement Marking Paint

1. Sherwin Williams ProMar Solvent Based Acrylic TM5712

PART 3 - EXECUTION

3.1 DEMOLITION

- A. Remove and dispose of all materials including asphalt, speedbumps and curbs as necessary to provide new materials as indicated in the plans and specifications.

3.2 GRINDING

- A. Grind all areas to be replaced.

3.3 EXAMINATION

- A. Verify that subgrade is dry and in suitable condition to support paving and imposed loads.

3.4 SURFACE PREPARATION

- A. General: Immediately before placing asphalt materials, remove loose and deleterious material from substrate surfaces. Ensure that prepared subgrade is ready to receive paving.
 1. Sweep loose granular particles from surface of unbound-aggregate base course. Do not dislodge or disturb aggregate embedded in compacted surface of base course.
- B. Level existing depressed asphalt surfaces as necessary to ensure adequate drainage.
- C. Use grindings as aggregate in all areas where additional fill is required and as necessary to building up areas to provide adequate drainage.
- D. Herbicide Treatment: Apply herbicide according to manufacturer's recommended rates and written application instructions. Apply to dry, prepared subgrade or surface of compacted-aggregate base before applying paving materials.
- E. Raise catch basin covers, manhole lids, and other covers to new level prior to asphalt placement.
- F. Provide speed bumps in the same location as those removed as part of an asphalt replacement.
- G. Remove wheel stops and reinstall after asphalt installation.

SPECIFICATIONS

**Asphalt Replacement
Woodland North**

Contract Number: TC2400131
Page 11 of 12

3.5 HOT-MIX ASPHALT PLACING

- A. Mechanically apply liquid tack coat to complete areas of overlay.
- B. Machine place hot-mix asphalt on prepared surface, spread uniformly, and strike off. Place asphalt mix by hand to areas inaccessible to equipment in a manner that prevents segregation of mix. Place each course to required grade, cross section, and thickness when compacted.
- C. Tack coat around all edges.

3.6 COMPACTION

- A. General: Begin compaction as soon as placed hot-mix paving will bear roller weight without excessive displacement. Compact hot-mix paving with hot, hand tampers or vibratory-plate compactors in areas inaccessible to rollers.
- B. Repairs: Remove paved areas that are defective or contaminated with foreign materials and replace with fresh, hot-mix asphalt. Compact by rolling to specified density and surface smoothness.
- C. Protection: After final rolling, do not permit vehicular traffic on pavement until it has cooled and hardened.
- D. Erect barricades to protect paving from traffic until mixture has cooled enough not to become marked.

3.7 DISPOSAL

- A. Except for material indicated to be recycled, remove excavated materials from Project site and legally dispose of them in an EPA-approved landfill.
 - 1. Do not allow excavated materials to accumulate on-site.

3.8 PAVEMENT MARKING

- A. Stripe to match existing including parking areas, parking stall designations, no parking areas, speedbumps, ADA logos and "Fire Lane" markings as required by the Authority having Jurisdiction.

3.9 INSPECTION

- A. After installation inspect to ensure that surface water in new areas drain to catch basins. Replace areas that do not drain correctly.

SPECIFICATIONS

**Asphalt Replacement
Woodland North**

Contract Number: TC2400131
Page 12 of 12

3.10 QUANTITIES

- A. Location numbers and estimated quantities are marked on the attached Asphalt Replacement Plans and at the site. These are estimated quantities only and bids shall be based on square foot (SF) areas marked at the properties. All quantities shall be verified by the Contractor.
- B. All curbing to be installed as shown on the plan sheet.
- C. All striping, stencils and numbers shall be repainted in the same configuration as existing.
- D. END OF SECTION 02741

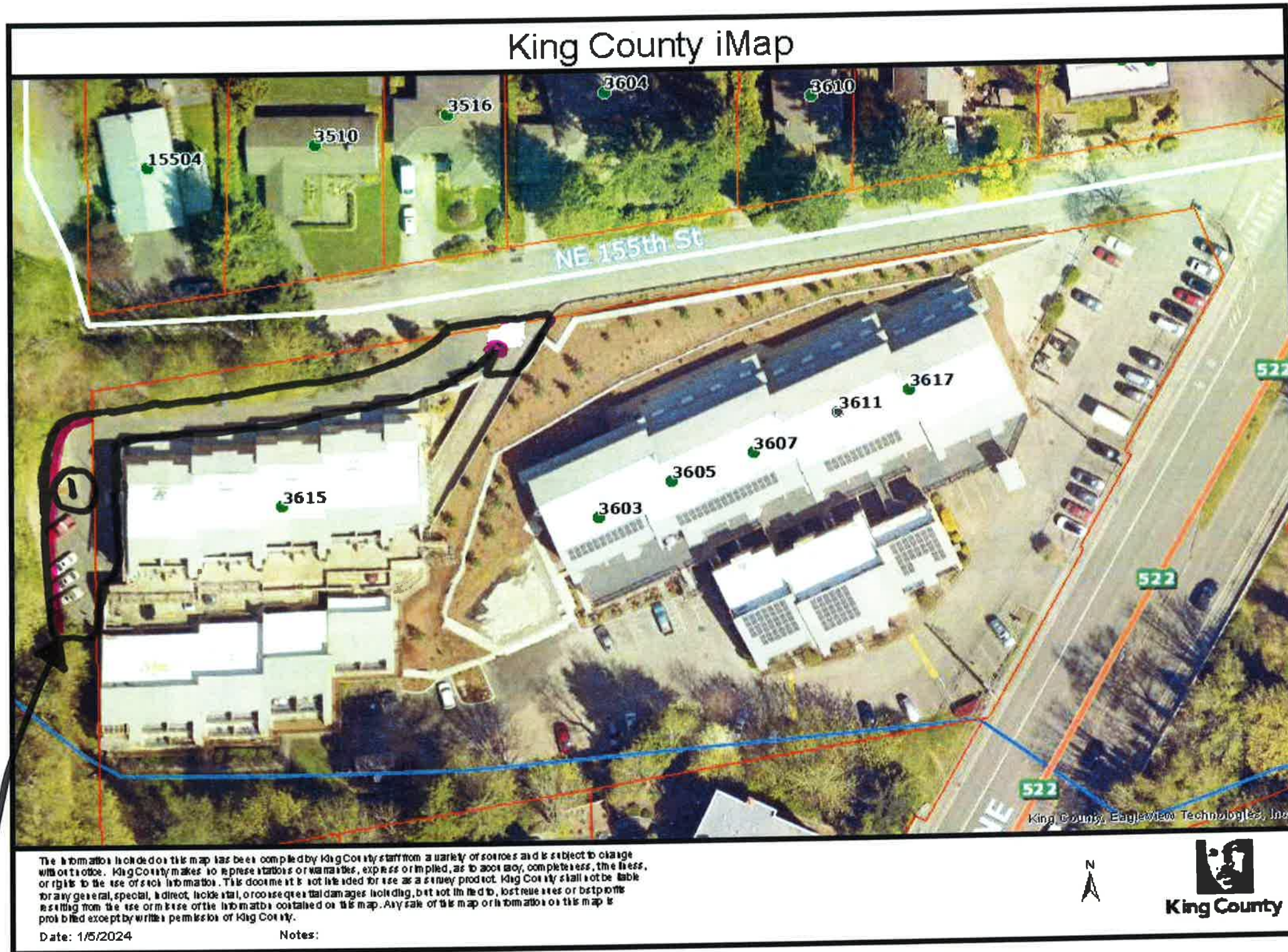

7825 sq ft approx (1) Mob Do Not Scale

— 160 lf vertical curb

30 lf extruded curb

WOODLAND NORTH APARTMENTS

3611 N.E. 155th St., Lake Forest Park, WA 98155

ASPHALT PAVING

Date: JANUARY 3, 2024

Revisions:

Drawn: Darrell Westlake

PLAN A1.0

INSTRUCTIONS TO BIDDERS

1.0 BIDDER RESPONSIBILITY CRITERIA

- A. It is the intent of Owner to award a contract to a responsible bidder submitting the lowest responsive bid. Before award, the bidder must meet the following bidder responsibility criteria to be considered a responsible bidder. The bidder may be required by the Owner to submit documentation demonstrating compliance with the criteria. The bidder must:
1. Have a current certificate of registration as a contractor in compliance with chapter 18.27 RCW, which must have been in effect at the time of bid submittal;
 2. Have a current Washington Unified Business Identifier (UBI) number;
 3. If applicable:
 - a. Have Industrial Insurance (workers' compensation) coverage for the bidder's employees working in Washington, as required in Title 51 RCW;
 - b. Have a Washington Employment Security Department number, as required in Title 50 RCW;
 - c. Have a Washington Department of Revenue state excise tax registration number, as required in Title 82 RCW;

1.1 SUBCONTRACTOR RESPONSIBILITY

- A. The Contractor shall include the language of this section in each of its first tier subcontracts, and shall require each of its subcontractors to include the same language of this section in each of their subcontracts, adjusting only as necessary the terms used for the contracting parties. Upon request of the Owner, the Contractor shall promptly provide documentation to the Owner demonstrating that the subcontractor meets the subcontractor responsibility criteria below. The requirements of this section apply to all subcontractors regardless of tier.
- B. At the time of subcontract execution, the Contractor shall verify that each of its first tier subcontractors meets the following bidder responsibility criteria:
1. Have a current certificate of registration in compliance with chapter 18.27 RCW, which must have been in effect at the time of subcontract bid submittal;
 2. Have a current Washington Unified Business Identifier (UBI) number;
 3. If applicable, have:
 - a. Have Industrial Insurance (workers' compensation) coverage for the subcontractor's employees working in Washington, as required in Title 51 RCW;
 - b. A Washington Employment Security Department number, as required in Title 50 RCW;
 - c. A Washington Department of Revenue state excise tax registration number, as required in Title 82 RCW;
 - d. An electrical contractor license, if required by Chapter 19.28 RCW;
 - e. An elevator contractor license, if required by Chapter 70.87 RCW.

1.2 SUPPLEMENTAL BIDDER RESPONSIBILITY CRITERIA

- A. For the work in this project a responsible/qualified Bidder must meet the following standards:

INSTRUCTIONS TO BIDDERS

1. Have a current certificate of registration as a contractor, in compliance with chapter 18.27 RCW, for the last three years under the same business name;
 2. Have a good record of past performance that includes, but is not limited to, high quality work, ability to complete projects on time, contractor's integrity, compliance with public policy, financial, contractual and tax obligations, as well as Federal and State rules and regulations in performing construction contracts.
 3. Have a current Experience Modification Rate (EMR) of 1.0 or less, or an average EMR rate of 1.0 or less over the last three years. The requirement may, at the Owner's sole discretion, be waived on review of a written explanation that includes details of accidents, L&I records, a Loss Ratio Report for the last five years, costs, dates of events, and changes that have been made by the contractor to reduce accidents. A current company Safety Plan shall also be reviewed.
 4. Bidder shall provide evidence of previous successful completion of Asphalt/Paving projects, of similar scope and complexity. Poor performance, lack of response, or failure to complete projects successfully within the contract time may be grounds for the rejection of bidder.
- B. Subcontractors shall have had three years minimum experience licensed in Washington State in the specific specialty contracting business.

1.3 PREPARATION OF BIDS – CONSTRUCTION

- A. Bids must be submitted on the Bid Form furnished by the Owner.
- B. All fields and questions on required forms must be fully answered and complete. Failure to do so may result in the bid being declared non-responsive.
- C. Bidders shall acknowledge receipt of all addenda to this solicitation by inserting the addenda numbers in the space provided on the Bid Form. Failure to do so may result in the bid being declared non-responsive.
 1. Bidder is responsible for ensuring that all addenda have been reviewed and included in their bid.
- D. In order for a bid to be considered responsive, bidders must submit the following signed documents with their bid package:
 1. Bid Form
 2. Bidder's Information Form
 3. Bid Guarantee
- E. The Bidder agrees to hold the base bid prices for sixty (60) days from date of bid opening.

1.4 BID GUARANTEE

- A. Not Required.

1.5 AMENDMENTS TO INVITATION TO BID

- A. If this solicitation is amended, then all terms and conditions which are not modified remain unchanged.

INSTRUCTIONS TO BIDDERS

1.6 PRE-BID MEETING

- A. All potential bidders are strongly encouraged to attend. Oral statements may not be relied upon and will not be binding or legally effective.

1.7 EXAMINATION OF PLANS, SPECIFICATIONS, AND SITE

- A. Before submitting a bid, the Bidder shall carefully examine each component of the Contract Documents prepared for the Work and any other available supporting data so as to be thoroughly familiar with all the requirements.
- B. The Bidder shall obtain copies of all agencies and associations guidelines and standards cited in the Contract Documents and necessary to perform the Work, including full size reproductions of material provided by Owner, at their own expense.
- C. The Bidder shall make a thorough and reasonable examination of the project site, facility and conditions under which the Work is to be performed, including but not limited to: Building access; resident occupancy; fire lanes; landscaping; obstacles and character of materials which may be encountered; traffic conditions; public and private utilities; the availability and cost of labor; and available facilities for transportation, handling, and storage of materials and equipment.

1.8 EXPLANATION TO PROSPECTIVE BIDDERS

- A. Any prospective bidder desiring an explanation or interpretation of the solicitation, drawings, specifications, etc., must submit a request in writing to the Owner seven (7) calendar days before the bid due date. Oral explanations or instructions given before the award of a contract will not be binding. Questions shall be submitted to:

Michelle Jackson
Woodland North LLLP
600 Andover Park West
Seattle, WA 98188
Email: MichelleJ@kcha.org

1.9 WAGE RATES

- A. Prevailing Wage Rates are included in the Bid Documents. Contractor shall pay no less than the rates indicated to all workers, laborers, or mechanics employed in the performance of any part of the Work.
 - 1. Residential rates may be used where available.
 - 2. The Contractor shall submit an Agreement to Pay Prevailing Wages to the Owner prior to start of Work.

1.10 TAXES

- A. All taxes imposed by law shall be included in the bid amount. The Contractor shall pay the WSST to the Department of Revenue and shall furnish proof of payment to the Owner if requested.

INSTRUCTIONS TO BIDDERS

- B. Washington State retail sales tax shall be included in the contract price.

1.11 ASSURANCE OF COMPLETION

- A. Payment and performance bonds for 100% of the Contract Sum, including all Change Orders and taxes imposed by law, shall be furnished for the Work, and shall be in a form acceptable to the Owner.
 - 1. On contracts of one hundred fifty thousand dollars (\$150,000.00) or less, the requirement for a Performance and Payment Bond may, at Contractors option, be waived in lieu of an additional 5% (total 10%) retainage.

1.12 BID ERROR

- A. In the event Bidder discovers an error in its bid, the Bidder may, under certain conditions and if before the date and time that bids are due, modify, their bid, as detailed below:
 - 1. Prior to Date and Time Bids are Due:
 - a. A Bidder may withdraw its bid at any time prior to the date and time bids are due upon written request.
 - b. After withdrawing an original submitted bid, a Bidder may modify and resubmit its bid at any time prior to the date and time bids are due.
 - 2. After the Date and Time Bids are Due:
 - a. A bidder who submits an erroneous low bid may withdraw the bid. The bid withdrawal is permissible if there was an obvious error in the low bid, and the mistake is readily apparent from the bid itself.
 - b. Notification: Provide to the Owner, within 24 hours of bid opening, written notification of the bidder's intent to withdraw the bid due to error.
 - c. Documentation: Provide to the Owner within 48 hours of bid opening, documentation sufficient in content to justify bid withdrawal to the satisfaction of the Owner. Include description and evidence of the error.
 - d. Approval: the Owner will approve or reject the request for withdrawal in writing.
 - e. Any low bidder who withdraws its bid is prohibited from bidding on the same project if it is subsequently re-solicited.

1.13 ADDITIVE OR DEDUCTIVE BID ITEMS

- A. The low bid, for purposes of award, shall be the lowest responsive bid from a qualified responsible bidder offering the low aggregate amount for the base bid, plus additive or deductive bid alternates selected by the Owner.

1.14 BID EVALUATION

- A. Responsive Bids: A bid will be considered responsive if it meets the conditions of the solicitation, in addition to but not limited to the following requirements:

INSTRUCTIONS TO BIDDERS

1. Bid is received not later than the time and date specified.
 2. Bid is submitted in the proper format on the form(s) provided.
 3. Bid includes the complete scope of work as defined in bid package.
 4. Bid does not include any exclusions or qualifications.
 5. Bid includes Unit and Lump Sum Costs as listed in Proposal Form.
 6. Forms are complete.
- B. After bid opening, bids will be checked for correctness of bid item prices, extensions and the total bid price. Discrepancies shall be resolved by accepting the bid item prices and the corrected extensions and total bid price.
- C. Responsible Bidders: the Owner will award contracts only to responsible bidders who demonstrate the ability to successfully perform under the terms and conditions as set forth in the Contract Documents and have successfully completed apartment renovation projects similar in scope and complexity.
1. Bidders must demonstrate relevant experience on similar types of projects and submit detailed information as required on the Bidder Information Form.
- D. The Owner reserves the right to contact references and investigate past performance and qualifications of the Bidder, subcontractor, and project team members, including contacting third parties and/or the references provided by the Bidder.
1. The Owner may contact references for other projects including those the Bidder did not identify and/or provided references.
 2. References may be asked to rate the performance of and describe their experience with project team members and subcontractors. Bidder Information may be solicited and evaluated on the following subjects: type and features of work; overall quality of project performance and quality of work; experience and technical knowledge and competence of the Bidder and Project Team Members; ability, capacity and skill to perform the Work; ability to manage submittals, requests for information, prevailing wage filings, and other paperwork; compliance with laws, ordinances, and contract provisions; and other information as deemed necessary.
 3. Poor reference(s) may be justification to determine a Bidder is not responsible.
- E. At the Owner's request, provide any additional explanation or information, which would assist in evaluating the qualifications of the Bidder, subcontractors, project team members, and bid price.
- F. The Owner will verify information submitted and if the lowest bidder is determined to be “not responsible,” the Owner will issue, in writing, the specific reasons for this determination. The bidder may appeal this decision. The appeal must be in writing and shall be delivered to the Owner within two business days. The appeal may include additional information that was not included in the original bid documents. Woodland North LLLP will make a final determination after the receipt of the appeal. The final determination may not be appealed.

1.15 CONTRACT AWARD

- A. Bonding and Insurance: Contract award will be contingent on ability to secure payment/performance bonding, and Contractor’s ability to meet the Owner insurance requirements as detailed in the Bid Documents.

INSTRUCTIONS TO BIDDERS

- B. Bonding, insurance and Agreement to Pay Prevailing Wage Rates shall be submitted to the Owner within 10 days of contract award.
- C. A Notice to Proceed shall be dated [NTP Date].
- D. Right to Reject Bids/Waiver: The Owner reserves the right to reject any or all bids or to waive any informalities or irregularities in the bidding.
- E. Retainage Funds: The Owner will not pay interest to the Contractor for accounts where retainage funds are maintained by the Owner. As part of the procurement by which the Contractor was selected for this work, the Contractor agrees to waive any other options and has made allowances for this waiver.

GENERAL CONDITIONS

PART 1 - GENERAL PROVISIONS

1.1 DEFINITIONS

- A. "Application for Payment" means a written request submitted by Contractor to Owner for payment of Work completed in accordance with the Contract Documents and approved Schedule of Values, supported by such substantiating data as Owner or A/E may require.
- B. "Architect," "Engineer," or "A/E" means a person or entity lawfully entitled to practice architecture or engineering, representing Owner within the limits of its delegated authority.
- C. "Authority Having Jurisdiction" or "AHJ" means a federal, state, local, or other regional department, or an individual such as a fire official, labor department, health department, building official, or other individual having statutory authority.
- D. "Change Order" means a written instrument signed by Owner and Contractor stating their agreement upon all of the following: (1) a change in the Work; (2) the amount of the adjustment in the Contract Sum, if any, and (3) the extent of the adjustment in the Contract Time, if any.
- E. "Claim" means Contractor's exclusive remedy for resolving disputes with Owner arising from the Contract Documents (including disputes regarding the terms of a Change Order or a request for equitable adjustment), as more fully set forth in Part 8.
- F. "Construction Schedule" means a schedule of the Work, in a form satisfactory to Owner, as further set forth in Part 3.2.
- G. "Contract Award Amount" is the sum of the Base Bid, any accepted Alternates, and Washington State Retail Sales Tax.
- H. "Contract Documents" means the Advertisement for Bids, Instructions for Bidders, completed Bid Form General Conditions, Modifications to the General Conditions, Supplemental Conditions, other Special Forms, Drawings and Specifications, the applicable wage rates, and all addenda and modifications thereof.
- I. "Contract Sum" is the total amount payable by Owner to Contractor for performance of the Work in accordance with the Contract Documents, including Washington State sales tax and all other taxes imposed by law and properly chargeable to the Work.
- J. "Contract Time" is the number of consecutive Days allotted in the Contract Documents for achieving Substantial Completion of the Work.
- K. "Contracting Officer" means the person delegated the authority by Owner to enter into, and/or terminate this Contract. The term includes any successor Contracting Officer and any duly authorized representative of the Contracting Officer.
- L. "Contractor" means the person or entity who has agreed with Owner to perform the Work in accordance with the Contract Documents.
- M. "Day" means calendar day, unless otherwise specified.
- N. "Drawings" are the graphic and pictorial portions of the Contract Documents showing the design, location, and dimensions of the Work, and may include plans, elevations, sections, details, schedules, and diagrams.
- O. "Final Acceptance" means the written acceptance issued to Contractor by Owner after Contractor has completed the requirements of the Contract Documents.
- P. "Final Completion" means that the Work is fully and finally complete in accordance with the Contract Documents.
- Q. "Force Majeure" means those acts entitling Contractor to request an equitable adjustment in the Contract Time, as more fully set forth in Part 3.5A.

GENERAL CONDITIONS

- R. "Furnish" means supply and deliver to Project site, ready for unloading, unpacking, assembly, installation, and similar operations.
- S. "Install" means operations at project site including unloading, temporarily storing, unpacking, assembling, erecting, placing, anchoring, applying, working to dimension, finishing, curing, protecting, cleaning, and similar operations.
- T. "Manager" means the person who is an authorized agent of the Owner to administer the Contract.
- U. "Notice" means a written notice which has been delivered in person to the individual or a member of the firm or entity or to an officer of the corporation for which it was intended or, if delivered or sent by registered or certified mail, to the last business address known to the party giving notice.
- V. "Notice to Proceed" means a notice from Owner to Contractor that defines the date on which the Contract Time begins to run.
- W. "Owner" means Woodland North LLLP or its authorized representative with the authority to enter into, administer, and/or terminate the Work in accordance with the Contract Documents and make related determinations and findings.
- X. "Person" means a corporation, partnership, business association of any kind, trust, company, or individual.
- Y. "Prior Occupancy" means Owner's use of all or parts of the Project before Substantial Completion, as more fully set forth in Part 6.7A.
- Z. "Provide" means furnish and install, complete and ready for the intended use.
- AA. "Construction Schedule" means a schedule of the Work, in a form satisfactory to Owner, as further set forth in Section Part 3.2.
- BB. "Project" means the total construction of which the Work performed in accordance with the Contract Documents may be the whole or a part and which may include construction by Owner or by separate contractors.
- CC. "Project Record" means the separate set of Drawings and Specifications as further set forth in Part 4.2A.
- DD. "Schedule of Values" means a written breakdown allocating the total Contract Sum to each principal category of Work, in such detail as requested by Owner.
- EE. "Specifications" are that portion of the Contract Documents consisting of the written requirements for materials, equipment, construction systems, standards and workmanship for the Work, and performance of related services.
- FF. "Subcontract" means a contract entered into by Subcontractor for the purpose of obtaining supplies, materials, equipment, or services of any kind for or in connection with the Work.
- GG. "Subcontractor" means any person, other than Contractor, who agrees to furnish or furnishes any supplies, materials, equipment, or services of any kind in connection with the Work.
- HH. "Substantial Completion" means that stage in the progress of the Work where the Owner has full and unrestricted use and benefit of the facilities for the purposes intended [when the construction is sufficiently complete], as more fully set forth in Part 6.6.
- II. "Work" means the construction and services required by the Contract Documents, and includes, but is not limited to, labor, materials, supplies, equipment, services, permits, and the manufacture and fabrication of components, performed, furnished, or provided in accordance with the Contract Documents.

1.2 EXECUTION AND INTENT

Contractor makes the following representations to Owner:

GENERAL CONDITIONS

- A. The Contract Sum is reasonable compensation for the Work and the Contract Time is adequate for the performance of the Work, as represented by the Contract Documents;
- B. Contractor has carefully reviewed the Contract Documents, had an opportunity to visit and examine the Project site, has become familiar with the local conditions in which the Work is to be performed, and has satisfied itself as to the nature, location, character, quality and quantity of the Work, the labor, materials, equipment, goods, supplies, work, services and other items to be furnished and all other requirements of the Contract Documents, as well as the surface and subsurface conditions and other matters that may be encountered at the Project site or affect performance of the Work or the cost or difficulty thereof.
- C. Contractor is financially solvent, able to pay its debts as they mature, and possesses sufficient working capital to complete the Work and perform Contractor's obligations required by the Contract Documents; and
- D. Contractor is able to furnish the plant, tools, materials, supplies, equipment and labor required to complete the Work and perform the obligations required by the Contract Documents and has sufficient experience and competence to do so.
- E. All work is to be executed in accordance with the Building Codes, as adopted by the Authority Having Jurisdiction, and other applicable codes and generally accepted industry standards.
- F. The Contract Documents are complementary. What is required by one part of the Contract Documents shall be binding as if required by all. Anything mentioned in the Specifications and not shown on the Drawings, or shown on the Drawings and not mentioned in the Specifications, shall be of like effect as if shown or mentioned in both.

PART 2 - INSURANCE AND BONDS

2.1 INSURANCE REQUIREMENTS FOR BUILDING TRADES CONTRACTORS

- A. Within 7 days from the date of the Notice of Award and prior to commencing Work, Contractor shall obtain, and maintain, for the duration of the Contract and for one year after Final Acceptance, insurance against claims for injuries to persons or damages to property that may arise from or in connection with the performance of the work hereunder by the Contractor, his agents, representatives, employees or Subcontractors. Contractor shall also maintain such insurance coverage during the performance of any corrective Work required by Part 5.15. Review of the Contractor's insurance by Owner shall not relieve or decrease the liability of Contractor.

2.2 MINIMUM SCOPE OF INSURANCE

- A. Contractors shall maintain coverages no less than:
 - 1. Insurance Services Office Commercial General Liability coverage.
 - 2. Insurance Services Office covering Automobile Liability, code 1 (any auto).
 - 3. Workers' Compensation insurance as required by State law and Employer's Liability Insurance.

2.3 MINIMUM LIMITS OF INSURANCE

- A. Contractor shall maintain limits no less than:
 - 1. General Liability: \$1,000,000 per occurrence for bodily injury, personal injury and property damage. If Commercial General Liability Insurance or other form with a general aggregate limit is used, either the general aggregate limit shall apply separately to this project/location or the general aggregate limit of \$2,000,000.
 - 2. Automobile Liability: \$1,000,000 per accident for bodily injury and property damage.
 - 3. Employer's Liability: \$1,000,000 per accident for bodily injury/sickness or disease.

2.4 DEDUCTIBLES AND SELF INSURED RETENTION

- A. Any deductibles or self-insured retentions must be declared to and approved by the Owner. At the option of the Owner, either: the insurer shall reduce or eliminate such deductibles or self-insured retentions as respects the Owner, its officers, officials, employees and volunteers; or the Contractor shall provide a financial guarantee

GENERAL CONDITIONS

satisfactory to the Owner guaranteeing payment of losses and related investigations, claim administration and defense expenses. **NOTE: If this contract deals with hazardous materials or activities (i.e. lead based paint, asbestos, armed security guards), additional provisions covering those exposures must be included in order to protect the Owner's interests.**

2.5 OTHER INSURANCE PROVISIONS

- A. The policies are to contain, or be endorsed to contain, the following provisions:
1. The Owner, the Property Manager, its officers, officials, employees, partners, agents and volunteers are to be covered as additional insureds under a "completed operations" type of additional insured endorsement with respect to general liability arising out of work or operations performed by or on behalf of the Contractor including materials, parts or equipment furnished in connection with such work or operations. The endorsement(s) effectuating the foregoing additional insured coverage shall be ISO form CG 20 10 11 85, or CG 20 10 10 01 issued concurrently with CG 20 37 10 01, or their equivalent as long as it provides additional insured coverage, without limitation, for (1) completed operations; (2) automobile liability arising out of vehicles owned, leased, hired, or borrowed by or on behalf of the Contractor; (3) any insurance written on a claims made basis, shall have a retroactive date that coincides with, or precedes, the commencement of any work under this contract. Evidence of such coverage shall be maintained for a minimum of six (6) years beyond the expiration of the project.
 2. The Owner will not accept Certificates of Insurance alone. Improperly completed endorsements will be returned to your insured for correction by an authorized representative of the insurance company.
 3. For any claims related to this project, the Contractor's insurance coverage shall be primary insurance as respects the Owner, its officers, officials, agents, partners, employees, and volunteers. Any insurance or self-insurance maintained or expired by the Owner, its officers, officials, agents, partners, employees, volunteers shall be excess of the Contractor's insurance and shall not contribute with it. Owner's Insurance is Non-Contributory in claims settlement funding.
 4. The "General description of agreement(s) and/or activity(s) insured" shall include reference to the activity and/or to Owner's specific project or site name, contract number, lease number, permit number or construction approval number.
 5. Each insurance policy required by this clause shall be endorsed to state that coverage shall not be canceled or materially changed, except after thirty (30) days' [ten (10) days for non-payment of premium] prior written notice, by certified mail, return receipt requested, has been given to the Owner.
 6. Maintenance of the proper insurance for the duration of the contract is a material element of the contract. Material changes in the required coverage or cancellation of the coverage shall constitute a material breach of the contract.

2.6 ACCEPTABILITY OF INSURERS

- A. Insurance is to be placed with insurers with a current A.M. Best's rating of no less than A:-VII. The name of the Insurance Company underwriting the coverage and its address shall be noted on the endorsement form. Contractors must provide written verification of their insurer's rating.

2.7 VERIFICATION OF COVERAGE

- A. Contractor shall furnish the Owner with original certificates and amendatory endorsements effecting coverage required by this clause. All certificates and endorsements are to be received and approved by the Owner before work commences in sufficient time to permit contractor to remedy any deficiencies. The Owner reserves the right to require complete, certified copies of all required insurance policies or pertinent parts thereof, including endorsements affecting the coverage, required by these specifications at any time. Contractor shall include in its bid the cost of all insurance and bonds required to complete the base bid work and accepted alternates.

2.8 SUBCONTRACTORS

- A. Subcontractors shall include the Contractor as additional insured under their policies. All coverage for subcontractors shall be subject to all of the requirements stated herein. Contractor shall be responsible for the adequacy of required coverages for subcontractors, and compile related certificates of insurance and endorsements evidencing subcontractors' compliance.

GENERAL CONDITIONS

2.9 PAYMENT AND PERFORMANCE BONDS

- A. Payment and performance bonds for 100% of the Contract Award Amount shall be furnished for the Work, using the Payment Bond and Performance Bond form AIA – form A312. Change order increases of cumulative 15% increments require revisions to the bond to match the new Contract Sum.
 - 1. On contracts of one hundred fifty thousand dollars (\$150,000.00) or less, the requirement for a Performance and Payment Bond may, at Contractors option, be waived in lieu of an additional 5% (total 10%) retainage.

PART 3 - TIME AND SCHEDULE

3.1 PROGRESS AND COMPLETION

- A. Contractor to meet schedule: Contractor shall diligently prosecute the Work, with adequate forces, achieve Substantial Completion within the Contract Time, and achieve Final Completion within a reasonable period thereafter.

3.2 CONSTRUCTION SCHEDULE

- A. Preliminary Progress Schedule: Unless otherwise provided in Division 1, Contractor shall, within seven Days after issuance of the Notice to Proceed, submit a preliminary Construction Schedule. The Construction Schedule shall show the sequence in which Contractor proposes to perform the Work and the dates on which Contractor plans to start and finish major portions of the Work, including dates for shop drawings and other submittals, and for acquiring materials and equipment.
- B. Form of Construction Schedule: Unless otherwise provided in Division 1, the Construction Schedule shall be in the form of a bar chart or critical path method analysis, as specified by Owner. The preliminary Construction Schedule may be general, showing the major portions of the Work, with a more detailed Construction Schedule submitted as directed by Owner.
- C. Owner comments on Construction Schedule: Owner shall return comments on the preliminary Construction Schedule to Contractor within 7 Days of receipt. Review by Owner of Contractor's schedule does not constitute an approval or acceptance of Contractor's construction means, methods, or sequencing, or its ability to complete the Work within the Contract Time. Contractor shall revise and resubmit its schedule, as necessary. Owner may withhold a portion of the progress payments until a Construction Schedule has been submitted which meets the requirements of this section.
- D. Monthly updates and compliance with Construction Schedule: Contractor shall utilize and comply with the Construction Schedule. On a monthly basis, or as otherwise directed by Owner, Contractor shall submit an updated Construction Schedule at its own expense to Owner indicating actual progress. If, in the opinion of Owner, Contractor is not in conformance with the Construction Schedule for reasons other than acts of Force Majeure as identified in Part 3.5, Contractor shall take such steps as are necessary to bring the actual completion dates of its work activities into conformance with the Construction Schedule, or revise the Construction Schedule to reconcile with the actual progress of the Work.
- E. Contractor to notify Owner of delays: Contractor shall promptly notify Owner in writing of any actual or anticipated event which is delaying or could delay achievement of any milestone or performance of any critical path activity of the Work. Contractor shall indicate the expected duration of the delay, the anticipated effect of the delay on the Construction Schedule, and the action being or to be taken to correct the problem. Provision of such notice does not relieve Contractor of its obligation to complete the Work within the Contract Time.

3.3 OWNER'S RIGHT TO SUSPEND THE WORK FOR CONVENIENCE

- A. Owner may suspend Work: Owner may, at its sole discretion, order Contractor, in writing, to suspend all or any part of the Work for up to 90 Days, or for such longer period as mutually agreed.
- B. Compliance with suspension; Owner's options: Upon receipt of a written notice suspending the Work, Contractor shall immediately comply with its terms and take all reasonable steps to minimize the incurrence of cost of

GENERAL CONDITIONS

performance directly attributable to such suspension. Within a period up to 90 Days after the notice is delivered to Contractor, or within any extension of that period to which the parties shall have agreed, Owner shall either:

1. Cancel the written notice suspending the Work; or
 2. Terminate the Work covered by the notice as provided in the termination provisions of Part 9.
- C. Resumption of Work: If a written notice suspending the Work is cancelled or the period of the notice or any extension thereof expires, Contractor shall resume Work.
- D. Equitable Adjustment for suspensions: Contractor shall be entitled to an equitable adjustment in the Contract Time, or Contract Sum, or both, for increases in the time or cost of performance directly attributable to such suspension, provided Contractor complies with all requirements set forth in Section 7.

3.4 OWNER'S RIGHT TO STOP THE WORK FOR CAUSE

- A. Owner may stop Work for Contractor's failure to perform: If Contractor fails or refuses to perform its obligations in accordance with the Contract Documents, Owner may order Contractor, in writing, to stop the Work, or any portion thereof, until satisfactory corrective action has been taken.
- B. No Equitable Adjustment for Contractor's failure to perform: Contractor shall not be entitled to an equitable adjustment in the Contract Time or Contract Sum for any increased cost or time of performance attributable to Contractor's failure or refusal to perform or from any reasonable remedial action taken by Owner based upon such failure.

3.5 DELAY

- A. Force Majeure actions not a default; Force Majeure defined: Any delay in or failure of performance by Owner or Contractor, other than the payment of money, shall not constitute a default hereunder if and to the extent the cause for such delay or failure of performance was unforeseeable and beyond the control of the party ("Force Majeure"). Acts of Force Majeure include, but are not limited to:
1. Acts of God or the public enemy;
 2. Acts or omissions of any government entity;
 3. Fire or other casualty for which Contractor is not responsible;
 4. Quarantine or epidemic;
 5. Strike or defensive lockout;
 6. Unusually severe weather conditions which could not have been reasonably anticipated; and
 7. Unusual delay in receipt of supplies or products which were ordered and expedited and for which no substitute reasonably acceptable to Owner was available.
- B. Contract Time adjustment for Force Majeure: Contractor shall be entitled to an equitable adjustment in the Contract Time for changes in the time of performance directly attributable to an act of Force Majeure, provided it makes a request for equitable adjustment according to Part 7.2A. Contractor shall not be entitled to an adjustment in the Contract Sum resulting from an act of Force Majeure.
- C. Contract Time or Contract Sum adjustment if Owner at fault: Contractor shall be entitled to an equitable adjustment in Contract Time, and may be entitled to an equitable adjustment in Contract Sum, if the cost or time of Contractor's performance is changed due to the fault or negligence of Owner, provided the Contractor makes a request according to Parts 7.2 and 7.2A.
- D. No Contract Time or Contract Sum adjustment if Contractor at fault: Contractor shall not be entitled to an adjustment in Contract Time or in the Contract Sum for any delay or failure of performance to the extent such delay or failure was caused by Contractor or anyone for whose acts Contractor is responsible.
- E. Contract Time adjustment only for concurrent fault: To the extent any delay or failure of performance was concurrently caused by the Owner and Contractor, Contractor shall be entitled to an adjustment in the Contract Time for that portion of the delay or failure of performance that was concurrently caused, provided it makes a request for equitable adjustment according to Section 7.2A, but shall not be entitled to an adjustment in Contract Sum.

GENERAL CONDITIONS

- F. Contractor to mitigate delay impacts: Contractor shall make all reasonable efforts to prevent and mitigate the effects of any delay, whether occasioned by an act of Force Majeure or otherwise.

3.6 NOTICE TO OWNER OF LABOR DISPUTES

- A. Contractor to notify Owner of labor disputes: If Contractor has knowledge that any actual or potential labor dispute is delaying or threatens to delay timely performance in accordance with the Contract Documents, Contractor shall immediately give notice, including all relevant information, to Owner.
- B. Pass through notification provisions to Subcontractors: Contractor agrees to insert a provision in its Subcontracts and to require insertion in all sub-subcontracts, that in the event timely performance of any such contract is delayed or threatened by delay by any actual or potential labor dispute, the Subcontractor or Sub-subcontractor shall immediately notify the next higher tier Subcontractor or Contractor, as the case may be, of all relevant information concerning the dispute.

3.7 DAMAGES FOR FAILURE TO ACHIEVE TIMELY COMPLETION

A. Liquidated Damages

1. Reason for Liquidated Damages: Timely performance and completion of the Work is essential to Owner and time limits stated in the Contract Documents are of the essence. Owner will incur serious and substantial damages if Substantial Completion of the Work does not occur within the Contract Time. However, it would be difficult if not impossible to determine the exact amount of such damages. Consequently, liquidated damages of \$500.00 per day will be assessed.
2. Calculation of Liquidated Damages amount: The liquidated damage amounts set forth above will be assessed not as a penalty, but as liquidated damages for breach of the Contract Documents. This amount is fixed and agreed upon by and between the Contractor and Owner because of the impracticability and extreme difficulty of fixing and ascertaining the actual damages the Owner would in such event sustain. This amount shall be construed as the actual amount of damages sustained by the Owner, and may be retained by the Owner and deducted from any payments to the Contractor.
3. Contractor responsible even if Liquidated Damages assessed: Assessment of liquidated damages shall not release Contractor from any further obligations or liabilities pursuant to the Contract Documents.
4. If different completion dates are specified in the contract for separate parts or stages of the Work, the amount of liquidated damages shall be assessed on those parts or stages which are delayed.

B. Actual Damages

1. Calculation of Actual Damages: Actual damages will be assessed for failure to achieve Final Completion within the time provided. Actual damages will be calculated on the basis of direct administrative, financial, and other related costs attributable to the Project from the date when Substantial Completion should have been achieved to the date Final Completion is actually achieved. The amount of these costs may be retained by Owner and deducted from any payment due Contractor.

PART 4 - SPECIFICATIONS, DRAWINGS, AND OTHER DOCUMENTS

4.1 DISCREPANCIES AND CONTRACT DOCUMENT REVIEW

- A. Specifications and Drawings are basis of the Work: The intent of the Specifications and Drawings is to describe a complete Project to be constructed in accordance with the Contract Documents. Contractor shall furnish all labor, materials, equipment, tools, transportation, permits, and supplies, and perform the Work required in accordance with the Drawings, Specifications, and other provisions of the Contract Documents.
- B. Parts of the Contract Documents are complementary: The Contract Documents are complementary. What is required by one part of the Contract Documents shall be binding as if required by all. Anything mentioned in the Specifications and not shown on the Drawings, or shown on the Drawings and not mentioned in the Specifications, shall be of like effect as if shown or mentioned in both.
- C. Contractor to report discrepancies in Contract Documents: Contractor shall carefully study and compare the Contract Documents with each other and with information furnished by Owner. If, during the performance of the

GENERAL CONDITIONS

Work, Contractor finds a conflict, error, inconsistency, or omission in the Contract Documents, it shall promptly and before proceeding with the Work affected thereby, report such conflict, error, inconsistency, or omission to Owner in writing.

- D. Contractor knowledge of discrepancy in documents – responsibility: Contractor shall do no Work without applicable Drawings, Specifications, or written modifications, or Shop Drawings where required, unless instructed to do so in writing by Owner. If Contractor performs any construction activity, and it knows or should have known that any of the Contract Documents contain a conflict, error, inconsistency, or omission, Contractor shall be responsible for the performance and shall bear the cost for its correction.
- E. Contractor to perform Work implied by Contract Documents: Contractor shall provide any work or materials the provision of which is clearly implied and is within the scope of the Contract Documents even if the Contract Documents do not mention them specifically.
- F. Interpretation questions referred to Owner: Questions regarding interpretation of the requirements of the Contract Documents shall be referred to the Owner.

4.2 PROJECT RECORD

- A. Contractor to maintain Project Record Drawings and Specifications: Contractor shall legibly mark in ink on a separate set of the Drawings and Specifications all actual construction, including depths of foundations, horizontal and vertical locations of internal and underground utilities and appurtenances referenced to permanent visible and accessible surface improvements, field changes of dimensions and details, actual suppliers, manufacturers and trade names, models of installed equipment, and Change Order Proposals (COP). This separate set of Drawings and Specifications shall be the “Project Record.”
- B. Update Project Record weekly and keep on site: The Project Record shall be maintained on the project site throughout the construction and shall be clearly labeled “PROJECT RECORD” The Project Record shall be updated at least weekly noting all changes and shall be available to Owner at all times.
- C. Final Project Record to A/E before Final Acceptance: Contractor shall submit the completed and finalized Project Record to Owner prior to Final Acceptance.

4.3 SHOP DRAWINGS

- A. Definition of Shop Drawings: “Shop Drawings” means documents and other information required to be submitted to Owner by Contractor pursuant to the Contract Documents, showing in detail: the proposed fabrication and assembly of structural elements; and the installation (i.e. form, fit, and attachment details) of materials and equipment. Shop Drawings include, but are not limited to, drawings, diagrams, layouts, schematics, descriptive literature, illustrations, schedules, performance and test data, samples, and similar materials furnished by Contractor to explain in detail specific portions of the Work required by the Contract Documents. For materials and equipment to be incorporated into the Work, Contractor submittal shall include the name of the manufacturer, the model number, and other information concerning the performance, capacity, nature, and rating of the item. When directed, Contractor shall submit all samples at its own expense. Owner may duplicate, use, and disclose Shop Drawings provided in accordance with the Contract Documents.
- B. Approval of Shop Drawings by Contractor and A/E: Contractor shall coordinate all Shop Drawings, and review them for accuracy, completeness, and compliance with the Contract Documents and shall indicate its approval thereon as evidence of such coordination and review. Where required by law, Shop Drawings shall be stamped by an appropriate professional licensed by the state of Washington. Shop Drawings submitted to Owner without evidence of Contractor’s approval shall be returned for resubmission. Contractor shall review, approve, and submit Shop Drawings with reasonable promptness and in such sequence as to cause no delay in the Work or in the activities of Owner or separate contractors. Contractor’s submittal schedule shall allow a reasonable time for A/E review. Owner will review, approve, or take other appropriate action on the Shop Drawings. Contractor shall perform no portion of the Work requiring submittal and review of Shop Drawings until the respective submittal has been reviewed and the Owner has approved or taken other appropriate action. Owner shall respond to Shop Drawing submittals with reasonable promptness. Any Work by Contractor shall be in accordance with reviewed Shop Drawings. Submittals made by Contractor which are not required by the Contract Documents may be returned without action.

GENERAL CONDITIONS

- C. Contractor not relieved of responsibility when Shop Drawings approved: Approval, or other appropriate action with regard to Shop Drawings, by Owner or A/E shall not relieve Contractor of responsibility for any errors or omissions in such Shop Drawings, nor from responsibility for compliance with the requirements of the Contract Documents. Unless specified in the Contract Documents, review by Owner or A/E shall not constitute an approval of the safety precautions employed by Contractor during construction, or constitute an approval of Contractor's means or methods of construction. If Contractor fails to obtain approval before installation and the item or work is subsequently rejected, Contractor shall be responsible for all costs of correction.
- D. Variations between Shop Drawings and Contract Documents: If Shop Drawings show variations from the requirements of the Contract Documents, Contractor shall describe such variations in writing, separate from the Shop Drawings, at the time it submits the Shop Drawings containing such variations. If Owner approves any such variation, an appropriate Change Order will be issued. If the variation is minor and does not involve an adjustment in the Contract Sum or Contract Time, a Change Order need not be issued; however, the modification shall be recorded upon the Project Record.
- E. Contractor to submit 4 copies of Shop Drawings: Unless otherwise provided in Division 1, Contractor shall submit to Owner for approval 4 copies of all Shop Drawings. Unless otherwise indicated, 3 sets of all Shop Drawings shall be retained by Owner and 1 set shall be returned to Contractor.

4.4 ORGANIZATION OF SPECIFICATIONS

- A. Specification organization by trade: Specifications are prepared in sections which conform generally with trade practices. These sections are for Owner and Contractor convenience and shall not control Contractor in dividing the Work among the Subcontractors or in establishing the extent of the Work to be performed by any trade.

PART 5 - PERFORMANCE

5.1 CONTRACTOR CONTROL AND SUPERVISION

- A. Contractor responsible for Means and Methods of construction: Contractor shall supervise and direct the Work, using its best skill and attention, and shall perform the Work in a skillful manner. Contractor shall be solely responsible for and have control over construction means, methods, techniques, sequences, and procedures and for coordinating all portions of the Work, unless the Contract Documents give other specific instructions concerning these matters. Contractor shall disclose its means and methods of construction when requested by Owner.
- B. Competent Superintendent required: Performance of the Work shall be directly supervised by a competent superintendent who has authority to act for Contractor. The superintendent must be satisfactory to the Owner and shall not be changed without the prior written consent of Owner. Owner may require Contractor to remove the superintendent from the Work or Project site, if Owner reasonably deems the superintendent incompetent, careless, or otherwise objectionable, provided Owner has first notified Contractor in writing and allowed a reasonable period for transition.
- C. Contractor responsible for acts and omissions of self and agents: Contractor shall be responsible to Owner for acts and omissions of Contractor, Subcontractors, and their employees and agents.
- D. Contractor to employ competent and disciplined workforce: Contractor shall enforce strict discipline and good order among all of the Contractor's employees and other persons performing the Work. Contractor shall not permit employment of persons not skilled in tasks assigned to them. Contractor's employees shall at all times conduct business in a manner which assures fair, equal, and nondiscriminatory treatment of all persons. Owner may, by written notice, request Contractor to remove from the Work or Project site any employee Owner reasonably deems incompetent, careless, or otherwise objectionable.
- E. Contractor to keep project documents on site: Contractor shall keep on the Project site a copy of the Drawings, Specifications, addenda, reviewed Shop Drawings, and permits and permit drawings.

GENERAL CONDITIONS

5.2 PERMITS, FEES, AND NOTICES

- A. Contractor to obtain and pay for permits: Unless otherwise provided in the Contract Documents, Contractor shall pay for and obtain all permits, licenses, and inspections necessary for proper execution and completion of the Work. Prior to Final Acceptance, the approved, signed permits shall be delivered to Owner.
- B. Allowances for permit fees: If allowances for permits or utility fees are called for in the Contract Documents and set forth in Contractor's bid, and the actual costs of those permits or fees differ from the allowances in the Contract Documents, the difference shall be adjusted by Change Order.
- C. Contractor to comply with all applicable laws: Contractor shall comply with and give notices required by all federal, state, and local laws, ordinances, rules, regulations, and lawful orders of public authorities applicable to performance of the Work.

5.3 PREVAILING WAGES

- A. Contractor to pay Prevailing Wages: Contractor shall pay the prevailing rate of wages to all workers, laborers, or mechanics employed in the performance of any part of the Work in accordance with the requirements of the Owner.
- B. Agreement to Pay Prevailing Wages: Before commencing the Work Contractor shall submit to the Owner an Agreement to Pay Prevailing Wages.
- C. Affidavit of Wages Paid: Prior to release of retainage, the Contractor shall submit to the Owner an Affidavit of Wages Paid, for the Contractor and every subcontractor, of any tier, that performed work on the Project.
- D. Disputes: Disputes regarding prevailing wage rates shall be referred to the Owner.
- E. Certified Payrolls: Contractor and any subcontractor shall submit a certified copy of payroll records if requested.

5.4 HOURS OF LABOR

- A. Overtime: Contractor shall comply with all applicable provisions of RCW 49.28 and they are incorporated herein by reference. Pursuant to that statute, no laborer, worker, or mechanic employed by Contractor, any Subcontractor, or any other person performing or contracting to do the whole or any part of the Work, shall be permitted or required to work more than eight hours in any one calendar day, provided, that in cases of extraordinary emergency, such as danger to life or property, the hours of work may be extended, but in such cases the rate of pay for time employed in excess of eight hours of each calendar day shall be not less than one and one-half times the rate allowed for this same amount of time during eight hours of service.

5.5 NONDISCRIMINATION

- A. During performance of the Work:
 - 1. Contractor shall not discriminate against any employee or applicant for employment because of race, creed, color, national origin, sex, age, marital status, the presence of any physical, sensory, or mental disability, sexual orientation, Vietnam-era veteran status, disabled veteran status or political affiliation, nor commit any unfair practices as defined in RCW 49.60.
 - 2. The Contractor shall take affirmative action to ensure that applicants are employed, and that employees are treated during employment without regard to their race, color, religion, sex, national origin, of any physical, sensory, or mental disability, sexual orientation, Vietnam-era veteran status, disabled veteran status, or political affiliation.
 - 3. The Contractor shall give all notices and comply with all applicable laws, ordinances, rules, regulations and orders in regard to Equal Employment Opportunity including but not limited to Executive Order 11246, as amended, Section 503 of the Rehabilitation Act of 1973, as amended, and the rules, regulations, and orders of the Secretary of Labor. The Contractor shall include the terms of this Clause in every subcontract so that such term shall be binding on each Subcontractor.
 - 4. Non-Discrimination R.C.W. 49.60: These special requirements establish minimum requirements for affirmative action and are intended to define and implement the basic discrimination provisions of these

GENERAL CONDITIONS

specifications. Failure to comply with these requirements may constitute grounds for application of contract default.

5.6 SAFETY PRECAUTIONS

- A. Contractor responsible for safety: Contractor shall be responsible for initiating, maintaining, and supervising all safety precautions and programs in connection with the performance of the Work.
- B. Contractor safety responsibilities: In carrying out its responsibilities according to the Contract Documents, Contractor shall protect the lives and health of employees performing the Work and other persons who may be affected by the Work; prevent damage to materials, supplies, and equipment whether on site or stored off-site; and prevent damage to other property at the site or adjacent thereto. Contractor shall comply with all applicable laws, ordinances, rules, regulations, and orders of any public body having jurisdiction for the safety of persons or property or to protect them from damage, injury, or loss; shall erect and maintain all necessary safeguards for such safety and protection; and shall notify owners of adjacent property and utilities when prosecution of the Work may affect them. For these purposes, the Contractor shall:
 - 1. Follow Washington Industrial Safety and Health Act (WISHA) regional directives and provide a site-specific safety program that will require an accident prevention and hazard analysis plan for the contractor and each subcontractor on the work site. The Contractor shall submit a site-specific safety plan to the Owner's representative prior to the initial scheduled construction meeting.
 - 2. Provide adequate safety devices and measures including, but not limited to, the appropriate safety literature, notice, training, permits, placement and use of barricades, signs, signal lights, ladders, scaffolding, staging, runways, hoist, construction elevators, shoring, temporary lighting, grounded outlets, wiring, hazardous materials, vehicles, construction processes, and equipment required by Chapter 19.27 RCW, State Building Code (Uniform Building, Electrical, Mechanical, Fire, and Plumbing Codes); Chapter 212-12 WAC, Fire Marshal Standards, Chapter 49.17 RCW, WISHA; Chapter 296-155 WAC, Safety Standards for Construction Work; Chapter 296-65 WAC; WISHA Asbestos Standard; WAC 296-62-071, Respirator Standard; WAC 296-62, General Occupation Health Standards, WAC 296-24, General Safety and Health Standards, WAC 296-24, General Safety and Health Standards, Chapter 49.70 RCW, and Right to Know Act.
 - 3. Comply with the State Environmental Policy Act (SEPA), Clean Air Act, Shoreline Management Act, and other applicable federal, state, and local statutes and regulations dealing with the prevention of environmental pollution and the preservation of public natural resources.
 - 4. Post all permits, notices, and/or approvals in a conspicuous location at the construction site.
 - 5. Provide any additional measures that the Owner determines to be reasonable and necessary for ensuring a safe environment in areas open to the public. Nothing in this part shall be construed as imposing a duty upon the Owner to prescribe safety conditions relating to employees, public, or agents of the Contractors.
- C. Contractor to maintain safety records: Contractor shall maintain an accurate record of exposure data on all incidents relating to the Work resulting in death, traumatic injury, occupational disease, or damage to property, materials, supplies, or equipment. Contractor shall immediately report any such incident to Owner. Owner shall, at all times, have a right of access to all records of exposure.
- D. Contractor to provide HazMat training: Contractor shall provide all persons working on the Project site with information and training on hazardous chemicals in their work at the time of their initial assignment, and whenever a new hazard is introduced into their work area.
 - 1. Information. At a minimum, Contractor shall inform persons working on the Project site of:
 - a. WAC: The requirements of chapter 296-62 WAC, General Occupational Health Standards;
 - b. Presence of hazardous chemicals: Any operations in their work area where hazardous chemicals are present; and
 - c. Hazard communications program: The location and availability of written hazard communication programs, including the required list(s) of hazardous chemicals and material safety data sheets required by chapter 296-62 WAC.
 - 2. Training. At a minimum, Contractor shall provide training for persons working on the Project site which includes:
 - a. Detecting hazardous chemicals: Methods and observations that may be used to detect the presence or release of a hazardous chemical in the work area (such as monitoring conducted by the

GENERAL CONDITIONS

- employer, continuous monitoring devices, visual appearance or odor of hazardous chemicals when being released, etc.);
 - b. Hazards of chemicals: The physical and health hazards of the chemicals in the work area;
 - c. Protection from hazards: The measures such persons can take to protect themselves from these hazards, including specific procedures Contractor, or its Subcontractors, or others have implemented to protect those on the Project site from exposure to hazardous chemicals, such as appropriate work practices, emergency procedures, and personal protective equipment to be used; and
 - d. Hazard communications program: The details of the hazard communications program developed by Contractor, or its Subcontractors, including an explanation of the labeling system and the material safety data sheet, and how employees can obtain and use the appropriate hazard information.
 - E. Hazardous, toxic or harmful substances: Contractor's responsibility for hazardous, toxic, or harmful substances shall include the following duties:
 - 1. Illegal use of dangerous substances: Contractor shall not keep, use, dispose, transport, generate, or sell on or about the Project site, any substances now or hereafter designated as, or which are subject to regulation as, hazardous, toxic, dangerous, or harmful by any federal, state or local law, regulation, statute or ordinance (hereinafter collectively referred to as "hazardous substances"), in violation of any such law, regulation, statute, or ordinance, but in no case shall any such hazardous substance be stored on the Project site.
 - 2. Contractor notifications of spills, failures, inspections, and fines: Contractor shall promptly notify Owner of all spills or releases of any hazardous substances which are otherwise required to be reported to any regulatory agency and pay the cost of cleanup. Contractor shall promptly notify Owner of all failures to comply with any federal, state, or local law, regulation, or ordinance; all inspections of the Project site by any regulatory entity concerning the same; all regulatory orders or fines; and all responses or interim cleanup actions taken by or proposed to be taken by any government entity or private party on the Project site.
 - F. Public safety and traffic: All Work shall be performed with due regard for the safety of the public. Contractor shall perform the Work so as to cause a minimum of interruption of vehicular traffic or inconvenience to pedestrians. All arrangements to care for such traffic shall be Contractor's responsibilities. All expenses involved in the maintenance of traffic by way of detours shall be borne by Contractor.
 - G. Contractor to act in an emergency: In an emergency affecting the safety of life or the Work or of adjoining property, Contractor is permitted to act, at its discretion, to prevent such threatened loss or injury, and Contractor shall so act if so authorized or instructed.
 - H. No duty of safety by Owner or A/E: Nothing provided in this section shall be construed as imposing any duty upon Owner or A/E with regard to, or as constituting any express or implied assumption of control or responsibility over, Project site safety, or over any other safety conditions relating to employees or agents of Contractor or any of its Subcontractors, or the public.
- 5.7 OPERATIONS, MATERIAL HANDLING, AND STORAGE AREAS
- A. Limited storage areas: Contractor shall confine all operations, including storage of materials, to Owner-approved areas.
 - B. Temporary buildings and utilities at Contractor expense: Temporary buildings (e.g., storage sheds, shops, offices) and utilities may be provided by Contractor only with the consent of Owner and without expense to Owner. The temporary buildings and utilities shall be removed by Contractor at its expense upon completion of the Work.
 - C. Roads and vehicle loads: Contractor shall use only established roadways or temporary roadways authorized by Owner. When materials are transported in prosecuting the Work, vehicles shall not be loaded beyond the loading capacity recommended by the manufacturer of the vehicle or prescribed by federal, state, or local law or regulation.
 - D. Ownership and reporting by Contractor of demolished materials: Ownership and control of all materials or facility components to be demolished or removed from the Project site by Contractor shall immediately vest in Contractor upon severance of the component from the facility or severance of the material from the Project site. Contractor shall be responsible for compliance with all laws governing the storage and ultimate disposal.

GENERAL CONDITIONS

Contractor shall provide Owner with a copy of all manifests and receipts evidencing proper disposal when required by Owner or applicable law.

- E. Contractor responsible for care of materials and equipment on-site: Contractor shall be responsible for the proper care and protection of its materials and equipment delivered to the Project site. Materials and equipment may be stored on the premises subject to approval of Owner. When Contractor uses any portion of the Project site as a shop, Contractor shall be responsible for any repairs, patching, or cleaning arising from such use.
- F. Contractor responsible for loss of materials and equipment: Contractor shall protect and be responsible for any damage or loss to the Work, or to the materials or equipment until the date of Final Acceptance, and shall repair or replace without cost to Owner any damage or loss that may occur.

5.8 PRIOR NOTICE OF EXCAVATION

- A. Excavation defined; Use of locator services: "Excavation" means an operation in which earth, rock, or other material on or below the ground is moved or otherwise displaced by any means, except the tilling of soil less than 12-inches in depth for agricultural purposes, or road ditch maintenance that does not change the original road grade or ditch flow line. Before commencing any excavation, Contractor shall engage a locate service for all underground facilities or utilities and provide notice of the scheduled commencement of excavation to all owners of underground facilities or utilities. Contractor shall pay all fees for locator services and pay for all damages caused by excavation.

5.9 UNFORESEEN PHYSICAL CONDITIONS

- A. Notice requirement for concealed or unknown conditions: If Contractor encounters conditions at the site which are subsurface or otherwise concealed physical conditions which differ materially from those indicated in the Contract Documents, or unknown physical conditions of an unusual nature which differ materially from those ordinarily found to exist and generally recognized as inherent in construction activities of the character provided for in the Contract Documents, then Contractor shall give written notice to Owner promptly and in no event later than 7 Days after the first observance of the conditions. Conditions shall not be disturbed prior to such notice.
- B. Adjustment in Contract Time and Contract Sum: If such conditions differ materially and cause a change in Contractor's cost of, or time required for, performance of any part of the Work, the Contractor may be entitled to an equitable adjustment in the Contract Time or Contract Sum, or both, provided it makes a request therefore as provided in Part 7.

5.10 PROTECTION OF EXISTING STRUCTURES, EQUIPMENT, VEGETATION, UTILITIES AND IMPROVEMENTS

- A. Contractor to protect and repair property: Contractor shall protect from damage all existing structures, equipment, improvements, utilities, and vegetation at or near the Project site; and on adjacent property of a third party, the locations of which are made known to or should be known by Contractor. Contractor shall repair any damage, including that to the property of a third party, resulting from failure to comply with the requirements of the Contract Documents or failure to exercise reasonable care in performing the Work. If Contractor fails or refuses to repair the damage promptly, Owner may have the necessary work performed and charge the cost to Contractor.
- B. Tree and vegetation protection: Contractor shall only remove trees when specifically authorized to do so, and shall protect vegetation that will remain in place.

5.11 LAYOUT OF WORK

- A. Advanced planning of the Work: Contractor shall plan and lay out the Work in advance of operations so as to coordinate all work without delay or revision.
- B. Layout responsibilities: Contractor shall lay out the Work from Owner-established baselines and bench marks indicated on the Drawings, and shall be responsible for all field measurements in connection with the layout. Contractor shall furnish, at its own expense, all stakes, templates, platforms, equipment, tools, materials, and labor required to lay out any part of the Work. Contractor shall be responsible for executing the Work to the lines and grades that may be established. Contractor shall be responsible for maintaining or restoring all stakes and other marks established.

GENERAL CONDITIONS

5.12 MATERIAL AND EQUIPMENT

- A. Contractor to provide new and equivalent equipment and materials: All equipment, material, and articles incorporated into the Work shall be new and of the most suitable grade for the purpose intended, unless otherwise specifically provided in the Contract Documents. References in the Specifications to equipment, material, articles, or patented processes by trade name, make, or catalog number, shall be regarded as establishing a standard quality and shall not be construed as limiting competition. Contractor may, at its option, use any equipment, material, article, or process that, in the judgment of Owner, is equal to that named in the Specifications, unless otherwise specifically provided in the Contract Documents.
- B. Contractor responsible for fitting parts together: Contractor shall do all cutting, fitting, or patching that may be required to make its several parts fit together properly, or receive or be received by work of others set forth in, or reasonably implied by, the Contract Documents. Contractor shall not endanger any work by cutting, excavating, or otherwise altering the Work and shall not cut or alter the work of any other contractor unless approved in advance by Owner.
- C. Owner may reject defective Work: Should any of the Work be found defective, or in any way not in accordance with the Contract Documents, this work, in whatever stage of completion, may be rejected by Owner.

5.13 AVAILABILITY AND USE OF UTILITY SERVICES

- A. Owner to provide and charge for utilities: Owner shall make all reasonable utilities available to Contractor from existing outlets and supplies, as specified in the Contract Documents. Unless otherwise provided in the Contract Documents, the utility service consumed shall be charged to or paid for by Contractor at prevailing rates charged to Owner or, where the utility is produced by Owner, at reasonable rates determined by Owner. Contractor will carefully conserve any utilities furnished.
- B. Contractor to install temporary connections and meters: Contractor shall, at its expense and in a skillful manner satisfactory to Owner, install and maintain all necessary temporary connections and distribution lines, together with appropriate protective devices, and all meters required to measure the amount of each utility used for the purpose of determining charges. Prior to the date of Final Acceptance, Contractor shall remove all temporary connections, distribution lines, meters, and associated equipment and materials.

5.14 TESTS AND INSPECTION

- A. Contractor to provide for all testing and inspection of Work: Contractor shall maintain an adequate testing and inspection program and perform such tests and inspections as are necessary or required to ensure that the Work conforms to the requirements of the Contract Documents. Contractor shall be responsible for inspection and quality surveillance of all its Work and all Work performed by any Subcontractor. Unless otherwise provided, Contractor shall make arrangements for such tests, inspections, and approvals with an independent testing laboratory or entity acceptable to Owner, or with the appropriate public authority, and shall bear all related costs of tests, inspections, and approvals. Contractor shall give Owner timely notice of when and where tests and inspections are to be made. Contractor shall maintain complete inspection records and make them available to Owner.
- B. Owner may conduct tests and inspections: Owner may, at any reasonable time, conduct such inspections and tests as it deems necessary to ensure that the Work is in accordance with the Contract Documents. Owner shall promptly notify Contractor if an inspection or test reveals that the Work is not in accordance with the Contract Documents. Unless the subject items are expressly accepted by Owner, such Owner inspection and tests are for the sole benefit of Owner and do not:
 - 1. Constitute or imply acceptance;
 - 2. Relieve Contractor of responsibility for providing adequate quality control measures;
 - 3. Relieve Contractor of responsibility for risk of loss or damage to the Work, materials, or equipment;
 - 4. Relieve Contractor of its responsibility to comply with the requirements of the Contract Documents; or
 - 5. Impair Owner's right to reject defective or nonconforming items, or to avail itself of any other remedy to which it may be entitled.
- C. Inspections or inspectors do not modify Contract Documents: Neither observations by an inspector retained by Owner, the presence or absence of such inspector on the site, nor inspections, tests, or approvals by others, shall

GENERAL CONDITIONS

relieve Contractor from any requirement of the Contract Documents, nor is any such inspector authorized to change any term or condition of the Contract Documents.

- D. Contractor responsibilities on inspections: Contractor shall promptly furnish, without additional charge, all facilities, labor, material and equipment reasonably needed for performing such safe and convenient inspections and tests as may be required by Owner. Owner may charge Contractor any additional cost of inspection or testing when Work is not ready at the time specified by Contractor for inspection or testing, or when prior rejection makes reinspection or retest necessary. Owner shall perform its inspections and tests in a manner that will cause no undue delay in the Work.

5.15 CORRECTION OF NONCONFORMING WORK

- A. Work covered by Contractor without inspection: If a portion of the Work is covered contrary to the requirements in the Contract Documents, it must, if required in writing by Owner, be uncovered for Owner's observation and be replaced at the Contractor's expense and without change in the Contract Time.
- B. Payment provisions for uncovering covered Work: If, at any time prior to Final Completion, Owner desires to examine the Work, or any portion of it, which has been covered, Owner may request to see such Work and it shall be uncovered by Contractor. If such Work is in accordance with the Contract Documents, the Contractor shall be entitled to an adjustment in the Contract Sum for the costs of uncovering and replacement, and, if completion of the Work is thereby delayed, an adjustment in the Contract Time, provided it makes such a request as provided in Part 7. If such Work is not in accordance with the Contract Documents, the Contractor shall pay the costs of examination and reconstruction.
- C. Contractor to correct and pay for non-conforming Work: Contractor shall promptly correct Work found by Owner not to conform to the requirements of the Contract Documents, whether observed before or after Substantial Completion and whether or not fabricated, installed, or completed. Contractor shall bear all costs of correcting such nonconforming Work, including additional testing and inspections.
- D. Contractor's compliance with warranty provisions: If, within one year after the date of Substantial Completion of the Work or designated portion thereof, or within one year after the date for commencement of any system warranties established under Part 6.7, or within the terms of any applicable special warranty required by the Contract Documents, any of the Work is found to be not in accordance with the requirements of the Contract Documents, Contractor shall correct it promptly after receipt of written notice from Owner to do so. Owner shall give such notice promptly after discovery of the condition. This period of one year shall be extended, with respect to portions of Work first performed after Substantial Completion, by the period of time between Substantial Completion and the actual performance of the Work. Contractor's duty to correct with respect to Work repaired or replaced shall run for one year from the date of repair or replacement. Obligations under this paragraph shall survive Final Acceptance.
- E. Contractor to remove non-conforming Work: Contractor shall remove from the Project site portions of the Work which are not in accordance with the requirements of the Contract Documents and are neither corrected by Contractor nor accepted by Owner.
- F. Owner may charge Contractor for non-conforming Work: If Contractor fails to correct nonconforming Work within a reasonable time after written notice to do so, Owner may replace, correct, or remove the nonconforming Work and charge the cost thereof to the Contractor.
- G. Contractor to pay for damaged Work during correction: Contractor shall bear the cost of correcting destroyed or damaged Work, whether completed or partially completed, caused by Contractor's correction or removal of Work which is not in accordance with the requirements of the Contract Documents.
- H. No Period of limitation on other requirements: Nothing contained in this section shall be construed to establish a period of limitation with respect to other obligations which Contractor might have according to the Contract Documents. Establishment of the time period of one year as described in Section 5.16D relates only to the specific obligation of Contractor to correct the Work, and has no relationship to the time within which the Contractor's obligation to comply with the Contract Documents may be sought to be enforced, including the time within which such proceedings may be commenced.
- I. Owner may accept non-conforming Work and charge Contractor: If Owner prefers to accept Work which is not in accordance with the requirements of the Contract Documents, Owner may do so instead of requiring its removal and correction, in which case the Contract Sum may be reduced as appropriate and equitable.

GENERAL CONDITIONS

5.16 CLEAN UP

- A. Contractor to keep site clean and leave it clean: Contractor shall at all times keep the Project site, including hauling routes, infrastructures, utilities, and storage areas, free from accumulations of waste materials. Before completing the Work, Contractor shall remove from the premises its rubbish, tools, scaffolding, equipment, and materials. Upon completing the Work, Contractor shall leave the Project site in a clean, neat, and orderly condition satisfactory to Owner. If Contractor fails to clean up as provided herein, and after reasonable notice from Owner, Owner may do so and the cost thereof shall be charged to Contractor.

5.17 ACCESS TO WORK

- A. Owner and A/E access to Work site: Contractor shall provide Owner and A/E access to the Work in progress wherever located.

5.18 OTHER CONTRACTS

- A. Owner may award other contracts; Contractor to cooperate: Owner may undertake or award other contracts for additional work at or near the Project site. Contractor shall reasonably cooperate with the other contractors and with Owner's employees and shall carefully adapt scheduling and perform the Work in accordance with these Contract Documents to reasonably accommodate the other work.

5.19 SUBCONTRACTORS AND SUPPLIERS

- A. Subcontractor Responsibility: The Contractor shall include the language of this paragraph in each of its first tier subcontracts, and shall require each of its subcontractors to include the same language of this section in each of their subcontracts, adjusting only as necessary the terms used for the contracting parties. Upon request of the Owner, the Contractor shall promptly provide documentation to the Owner demonstrating that the subcontractor meets the subcontractor responsibility criteria below. The requirements of this paragraph apply to all subcontractors regardless of tier. At the time of subcontract execution, the Contractor shall verify that each of its first tier subcontractors meets the following bidder responsibility criteria:
 - 1. Have a current certificate of registration as a contractor in compliance with chapter 18.27 RCW, which must have been in effect at the time of subcontract bid submittal;
 - 2. Have a current Washington Unified Business Identifier (UBI) number;
 - 3. If applicable, have:
 - a. Industrial Insurance (workers' compensation) coverage for the subcontractor's employees working in Washington, as required in Title 51 RCW;
 - b. A Washington Employment Security Department number, as required in Title 50 RCW;
 - c. A Washington Department of Revenue state excise tax registration number, as required in Title 82 RCW;
 - d. An electrical contractor license, if required by Chapter 19.28 RCW;
 - e. An elevator contractor license, if required by Chapter 70.87 RCW.
- B. Provide names of Subcontractors and use qualified firms: Before submitting the first Application for Payment, Contractor shall furnish in writing to Owner the names, addresses, and telephone numbers of all Subcontractors, as well as suppliers. Contractor shall utilize Subcontractors and suppliers which are experienced and qualified, and meet the requirements of the Contract Documents, if any. Contractor shall not utilize any Subcontractor or supplier to whom the Owner has a reasonable objection, and shall obtain Owner's written consent before making any substitutions or additions.
- C. Subcontracts in writing and pass through provision: All Subcontracts must be in writing. By appropriate written agreement, Contractor shall require each Subcontractor, so far as applicable to the Work to be performed by the Subcontractor, to be bound to Contractor by terms of the Contract Documents, and to assume toward Contractor all the obligations and responsibilities which Contractor assumes toward Owner in accordance with the Contract Documents. Each Subcontract shall preserve and protect the rights of Owner in accordance with the Contract Documents with respect to the Work to be performed by the Subcontractor so that subcontracting thereof will not prejudice such rights. Contractor shall require each Subcontractor to enter into similar agreements with Sub-subcontractors. However, nothing in this paragraph shall be construed to alter the contractual relations between Contractor and its Subcontractors with respect to insurance or bonds.

GENERAL CONDITIONS

- D. Coordination of Subcontractors; Contractor responsible for Work: Contractor shall schedule, supervise, and coordinate the operations of all Subcontractors. No Subcontracting of any of the Work shall relieve Contractor from its responsibility for the performance of the Work in accordance with the Contract Documents or any other obligations of the Contract Documents.
- E. Automatic assignment of subcontracts: Each subcontract agreement for a portion of the Work is hereby assigned by Contractor to Owner provided that:
 - 1. Effective only after termination and Owner approval: The assignment is effective only after termination by Owner for cause pursuant to Part 9.1 and only for those Subcontracts which Owner accepts by notifying the Subcontractor in writing; and
 - 2. Owner assumes Contractor's responsibilities: After the assignment is effective, Owner will assume all future duties and obligations toward the Subcontractor which Contractor assumed in the Subcontract.
 - 3. Impact of bond: The assignment is subject to the prior rights of the surety, if any, obligated under any bond provided in accordance with the Contract Documents.

5.20 WARRANTY OF CONSTRUCTION

- A. Contractor warranty of Work: In addition to any special warranties provided elsewhere in the Contract Documents, Contractor warrants that all Work conforms to the requirements of the Contract Documents and is free of any defect in equipment, material, or design furnished, or workmanship performed by Contractor.
- B. Contractor responsibilities: With respect to all warranties, express or implied, for Work performed or materials furnished according to the Contract Documents, Contractor shall:
 - 1. Obtain warranties: Obtain all warranties that would be given in normal commercial practice;
 - 2. Warranties for benefit of Owner: Require all warranties to be executed, in writing, for the benefit of Owner;
 - 3. Enforcement of warranties: Enforce all warranties for the benefit of Owner, if directed by Owner; and
 - 4. Contractor responsibility for subcontractor warranties: Be responsible to enforce any subcontractor's, manufacturer's, or supplier's warranties should they extend beyond the period specified in the Contract Documents.
- C. Warranties beyond Final Acceptance: The obligations under this section shall survive Final Acceptance.

5.21 INDEMNIFICATION

- A. The Contractor hereby agrees to indemnify, defend, and hold harmless the Owner, its successors and assigns, directors, officers, officials, employees, agents, partners and volunteers (all foregoing singly and collectively "Indemnitees") from and against any and all claims, losses, harm, costs, liabilities, damages and expenses, including, but not limited to, reasonable attorney's fees, arising or resulting from the performance of the services, or the acts or omissions of the Contractor its successors, and assigns, employees, subcontractors or anyone acting on the contractor's behalf in connection with the Contract Documents or its performance thereof.
- B. Provided, however, that the Contractor will not be required to indemnify, defend, or save harmless the indemnitee as provided in the preceding paragraphs of this section if the claim, suit, or action for injuries, death, or damages is caused by the sole negligence of the indemnitee. Where such claims, suites, or actions result from the concurrent negligence of (a) the Indemnitee or the Indemnitee's agents or employees and (b) the Contractor or the Contractor's agents or employees, the indemnity provisions provided in the preceding paragraphs of this section shall be valid and enforceable only to the extent of the Contractor's negligence or the negligence of its agents and employees..
- C. The foregoing indemnity is specifically and expressly intended to constitute a waiver of the Contractor's immunity under Washington's Industrial Insurance act, RCW Title 51. The parties acknowledge that these provisions were specifically negotiated and agreed upon by them. If any portion of this indemnity clause is invalid or unenforceable, it shall be deemed excised and the remaining portions of the clause shall be given full force and effect.
- D. The Contractor hereby agrees to require all its Subcontractors or anyone acting under its direction or control or on its behalf in connection with or incidental to the performance of the Contract Documents to execute an

GENERAL CONDITIONS

indemnity clause identical to the preceding clauses, specifically naming the Indemnitees as indemnitee, and failure to do so shall constitute a material breach of the Contract Documents by the Contractor.

PART 6 - PAYMENTS AND COMPLETION

6.1 CONTRACT SUM

- A. Taxes: The Contract Sum shall include all taxes imposed by law and properly chargeable to the Project, including retail sales tax. The contractor shall pay the WSST to the Department of Revenue and shall furnish proof of payment to the Owner if requested.

6.2 SCHEDULE OF VALUES

- A. Contractor to submit Schedule of Values: Before submitting its first Application for Payment, Contractor shall submit to Owner for approval a breakdown allocating the total Contract Sum to each principal category of work, in such detail as requested by Owner (“Schedule of Values”). The approved Schedule of Values shall include appropriate amounts for demobilization, record drawings, O&M manuals, and any other requirements for Project closeout, and shall be used by Owner as the basis for progress payments. Payment for Work shall be made only for and in accordance with those items included in the Schedule of Values.

6.3 APPLICATION FOR PAYMENT

- A. Monthly Application for Payment with substantiation: At monthly intervals, unless determined otherwise by Owner, Contractor shall submit to Owner an itemized Application for Payment for Work completed in accordance with the Contract Documents and the approved Schedule of Values. Each application shall be supported by such substantiating data as Owner may require.
- B. Contractor certifies Subcontractors paid: By submitting an Application for Payment, Contractor is certifying that all Subcontractors have been paid, less earned retainage, as their interests appeared in the last preceding certificate of payment. By submitting an Application for Payment, Contractor is recertifying that the representations set forth in Part 1.2, are true and correct, to the best of Contractor’s knowledge, as of the date of the Application for Payment.
- C. Reconciliation of Work with Progress Schedule: At the time it submits an Application for Payment, Contractor shall analyze and reconcile, to the satisfaction of Owner, the actual progress of the Work with the Progress Schedule. Each Application for Payment shall be consistent with previous applications and payments.
- D. Payment for material delivered to site or stored off-site: If authorized by Owner, the Application for Payment may include request for payment for material delivered to the Project site and suitably stored, or for completed preparatory work. Payment may similarly be requested for material stored off the Project site, provided Contractor complies with or furnishes satisfactory evidence of the following:
 - 1. Suitable facility or location: The material will be placed in a facility or location that is structurally sound, dry, lighted and suitable for the materials to be stored;
 - 2. Facility or location within 10 miles of Project: The facility or location is located within a 10-mile radius of the Project. Other locations may be utilized, if approved in writing, by Owner;
 - 3. Facility or location exclusive to Project’s materials: Only materials for the Project are stored within the facility or location (or a secure portion of a facility or location set aside for the Project);
 - 4. Insurance provided on materials in facility or location: Contractor furnishes Owner a certificate of insurance extending Contractor’s insurance coverage for damage, fire, and theft to cover the full value of all materials stored, or in transit;
 - 5. Facility or location locked and secure: The facility or location (or secure portion thereof) is continuously under lock and key, and only Contractor’s authorized personnel shall have access;
 - 6. Owner right of access to facility or location: Owner shall at all times have the right of access in company of Contractor;
 - 7. Contractor assumes total responsibility for stored materials: Contractor and its surety assume total responsibility for the stored materials; and
 - 8. Contractor provides documentation and Notice when materials moved to site: Contractor furnishes to Owner certified lists of materials stored, bills of lading, invoices, and other information as may be

GENERAL CONDITIONS

required, and shall also furnish Notice to Owner when materials are moved from storage to the Project site.

6.4 PROGRESS PAYMENTS

- A. Owner to pay within 30 Days: Owner shall make progress payments, in such amounts as Owner determines are properly due, within 30 Days after receipt of a properly executed Application for Payment. Owner shall notify Contractor if the Application for Payment does not comply with the requirements of the Contract Documents.
- B. Withholding retainage; Options for retainage: Owner shall retain 5% of the amount of each progress payment until 45 Days after Final Acceptance and receipt of all documents required by law or the Contract Documents, including consent of surety to release of the retainage. The Owner will not pay interest to the Contractor for accounts where retainage funds are maintained by the Owner. The Contractor agrees to waive any other options and has made allowances for this waiver. Owner may permit Contractor to provide an appropriate bond in lieu of the retained funds.
- C. Title passes to Owner upon payment: Title to all Work and materials covered by a progress payment shall pass to Owner at the time of such payment free and clear of all liens, claims, security interests, and encumbrances. Passage of title shall not, however, relieve Contractor from any of its duties and responsibilities for the Work or materials, or waive any rights of Owner to insist on full compliance by Contractor with the Contract Documents.
- D. Waivers of Lien: With each Application for Payment, submit conditional waivers lien from every entity who is lawfully entitled to file a lien arising out of the Work covered by the payment.
 - 1. Submit partial waivers on each item for amount requested, before deduction for retainage, on each item.
 - 2. When an application shows completion of an item, submit final or full waivers.
 - 3. Owner reserves the right to designate which entities involved in the Work must submit waivers.
 - a. Submit final Application for Payment with or preceded by final waivers from every entity involved with performance of the Work covered by the application who is lawfully entitled to a lien.
- E. Final Payment Application: Submit final Application for Payment with releases and close out supporting documentation.
- F. Approved payments shall be mailed to the Contractor within 30 days.

6.5 PAYMENTS WITHHELD

- A. Owner's right to withhold payment: Owner may withhold or, on account of subsequently discovered evidence, nullify the whole or part of any payment to such extent as may be necessary to protect Owner from loss or damage for reasons including but not limited to:
 - 1. Non-compliant Work: Work not in accordance with the Contract Documents;
 - 2. Remaining Work to cost more than unpaid balance: Reasonable evidence that the Work required by the Contract Documents cannot be completed for the unpaid balance of the Contract Sum;
 - 3. Owner correction or completion Work: Work by Owner to correct defective Work or complete the Work in accordance with Section 5.15;
 - 4. Contractor's failure to perform: Contractor's failure to perform in accordance with the Contract Documents; or
 - 5. Contractor's negligent acts or omissions: Cost or liability that may occur to Owner as the result of Contractor's fault or negligent acts or omissions.
- B. Owner to notify Contractor of withholding for unsatisfactory performance: In any case where part or all of a payment is going to be withheld for unsatisfactory performance, Owner shall notify Contractor.

6.6 SUBSTANTIAL COMPLETION

- A. Substantial Completion defined: Substantial Completion is the stage in the progress of the Work when the construction is sufficiently complete, in accordance with the Contract Documents, so Owner has full and unrestricted use and benefit of the facilities for the use for which it is intended. All Work other than incidental

GENERAL CONDITIONS

corrective or punch list work shall be completed. Substantial Completion shall not have been achieved if all systems and parts are not functional, if utilities are not connected and operating normally, if all required occupancy permits have not been issued, or if the Work is not accessible by normal vehicular and pedestrian traffic routes. The date Substantial Completion is achieved shall be established in writing by Owner. Contractor may request an early date of Substantial Completion which must be approved by Change Order. Owner's occupancy of the Work or designated portion thereof does not necessarily indicate that Substantial Completion has been achieved.

6.7 PRIOR OCCUPANCY

- A. Prior Occupancy defined; Restrictions: Owner may, upon written notice thereof to Contractor, take possession of or use any completed or partially completed portion of the Work ("Prior Occupancy") at any time prior to Substantial Completion. Unless otherwise agreed in writing, Prior Occupancy shall not: be deemed an acceptance of any portion of the Work; accelerate the time for any payment to Contractor; prejudice any rights of Owner provided by any insurance, bond, guaranty, or the Contract Documents; relieve Contractor of the risk of loss or any of the obligations established by the Contract Documents; establish a date for termination or partial termination of the assessment of liquidated damages; or constitute a waiver of claims.
- B. Damage; Duty to repair and warranties: Notwithstanding anything in the preceding paragraph, Owner shall be responsible for loss of or damage to the Work resulting from Prior Occupancy. Contractor's one year duty to repair any system warranties shall begin on building systems activated and used by Owner as agreed in writing by Owner and Contractor.

6.8 FINAL COMPLETION, ACCEPTANCE, AND PAYMENT

- A. Final Completion defined: Final Completion shall be achieved when the Work is fully and finally complete in accordance with the Contract Documents. The date Final Completion is achieved shall be established by a final inspection of the Work by Owner following receipt of (1) written notice from the Contractor that the Work is ready for final inspection and (2) a final Application for Payment. When the Owner finds the Work acceptable and fully performed under the Contract Documents and the Contractor has delivered to the Owner all warranties, permits, and operations manuals, the Owner will issue a Notice of Final Completion. In no case shall Final Completion constitute Final Acceptance which is a subsequent, separate, and distinct action.
- B. Final Acceptance defined: Final Acceptance shall be achieved when the Contractor has completed the requirements of the Contract Documents. The date Final Acceptance is achieved shall be established by Owner in writing. Prior to Final Acceptance, Contractor shall, in addition to all other requirements in the Contract Documents, submit to Owner a written notice of any outstanding disputes or claims between Contractor and any of its Subcontractors, including the amounts and other details thereof. Neither Final Acceptance, nor final payment, shall release Contractor or its sureties from any obligations of these Contract Documents or the payment and performance bonds, or constitute a waiver of any claims by Owner arising from Contractor's failure to perform the Work in accordance with the Contract Documents.
- C. Final payment waives Claim rights: Acceptance of final payment by Contractor, or any Subcontractor, shall constitute a waiver and release to Owner of all claims by Contractor, or any such Subcontractor, for an increase in the Contract Sum or the Contract Time, and for every act or omission of Owner relating to or arising out of the Work, except for those Claims made in accordance with the procedures, including the time limits, set forth in Part 8.

PART 7 - CHANGES

7.1 CHANGE IN THE WORK

- A. Changes in Work, Contract Sum, and Contract Time by Change Order: Owner may, at any time and without notice to Contractor's surety, order additions, deletions, revisions, or other changes in the Work. These changes in the Work shall be incorporated into the Contract Documents through the execution of Change Orders. If any change in the Work ordered by Owner causes an increase or decrease in the Contract Sum or the Contract Time, an equitable adjustment shall be made as provided in Section 7.2 or 7.2A, respectively, and such adjustment(s) shall be incorporated into a Change Order.

GENERAL CONDITIONS

- B. Owner may request COP from Contractor: If Owner desires to order a change in the Work, it may request a written Change Order Proposal (COP) from Contractor. Contractor shall submit a Change Order Proposal within 7 Days of the request from Owner, or within such other period as mutually agreed. Contractor's Change Order Proposal shall be full compensation for implementing the proposed change in the Work, including any adjustment in the Contract Sum or Contract Time, and including compensation for all delays in connection with such change in the Work and for any expense or inconvenience, disruption of schedule, or loss of efficiency or productivity occasioned by the change in the Work.
- C. COP negotiations: Upon receipt of the Change Order Proposal, or a request for equitable adjustment in the Contract Sum or Contract Time, or both, as provided in Sections 7.2 and 7.3, Owner may accept or reject the proposal, request further documentation, or negotiate acceptable terms with Contractor. Pending agreement on the terms of the Change Order, Owner may direct Contractor to proceed immediately with the Change Order Work. Contractor shall not proceed with any change in the Work until it has obtained Owner's approval. All Work done pursuant to any Owner-directed change in the Work shall be executed in accordance with the Contract Documents.
- D. Change Order as full payment and final settlement: If Owner and Contractor reach agreement on the terms of any change in the Work, including any adjustment in the Contract Sum or Contract Time, such agreement shall be incorporated in a Change Order. The Change Order shall constitute full payment and final settlement of all claims for time and for direct, indirect, and consequential costs, including costs of delays, inconvenience, disruption of schedule, or loss of efficiency or productivity, related to any Work either covered or affected by the Change Order, or related to the events giving rise to the request for equitable adjustment.
- E. Failure to agree upon terms of Change Order; Final offer and Claims: If Owner and Contractor are unable to reach agreement on the terms of any change in the Work, including any adjustment in the Contract Sum or Contract Time, Contractor may at any time in writing, request a final offer from Owner. Owner shall provide Contractor with its written response within 30 Days of Contractor's request. Owner may also provide Contractor with a final offer at any time. If Contractor rejects Owner's final offer, or the parties are otherwise unable to reach agreement, Contractor's only remedy shall be to file a Claim as provided in Part 8.
- F. Field Authorizations: The Owner may direct the Contractor to proceed with a change in the work through a written Field Authorization when the time required to price and execute a Change Order would impact the Project.

The Field Authorization shall describe and include the following:

1. The scope of work
2. An agreed upon maximum not-to-exceed amount
3. Any estimated change to the Contract Time
4. The method of final cost determination in accordance with the requirements of Part 7 of the General Conditions
5. The supporting cost data to be submitted in accordance with the requirements of Part 7 of the General Conditions

Upon satisfactory submittal by the Contractor and approval by the Owner of supporting cost data, a Change Order will be executed. The Owner will not make payment to the Contractor for Field Authorization work until that work has been incorporated into an executed Change Order.

7.2 CHANGE IN THE CONTRACT SUM

- A. Change Order Pricing - Fixed Price: When the fixed price or time and materials method is used to determine the value of any Work covered by a Change Order, or of a request for an equitable adjustment in the Contract Sum, the following procedures shall apply:
 1. Contractor's Change Order proposal, or request for adjustment in the Contract Sum, shall be accompanied by a complete itemization of the costs, including labor, material, subcontractor costs, and overhead and profit. The costs shall be itemized in the manner set forth below, and shall be submitted on breakdown sheets with documentation in a form approved by Owner.
 2. Any request for adjustment of Contract Sum shall include only the following items:
 - a. Craft labor costs for Contractors and Subcontractors.

GENERAL CONDITIONS

- 1) Basic wages and benefits: Hourly rates and benefits according to applicable prevailing wages.
 - 2) Direct supervision shall not to exceed 15% of the cost of direct labor. No supervision markup shall be allowed for a working supervisor's hours.
 - 3) Worker's Insurance. Direct contributions to the State for industrial insurance, medical aid, and supplemental pension by the class and rates established by L&I.
 - 4) Federal Insurance. Direct contributions required by the Federal Insurance Compensation Act; Federal Unemployment Tax Act; and the State Unemployment Compensation Act.
 - 5) Safety and small tools: 4% of the sum of the amounts calculated in (1), (2), and (3) above.
- b. Material Costs: Material costs shall be developed from actual known costs, supplier quotations or standard industry pricing guides and shall consider all available discounts. Freight costs, express charges, or special delivery charges shall be itemized.
- c. Equipment Costs: Itemization of the type of equipment and the estimated or actual length of time the equipment appropriate for the Work is or will be used on the change in the Work. Costs will be allowed for equipment only if used solely for the changed Work, or for additional rental costs actually incurred by the Contractor. The Date Quest Rental Rate (Blue Book) shall be used as a basis for establishing rental rates of equipment not listed in the above sources. The maximum rate for standby equipment shall not exceed 50% of the applicable rate.
- d. Allowance for Overhead: This allowance shall compensate Contractor for all noncraft labor, temporary construction facilities, field engineering, schedule updating, as-built drawings, home office cost, B&O taxes, office engineering, estimating costs, additional overhead because of extended time and any other cost incidental to the change in the Work. This allowance shall be strictly limited in all cases an amount not to exceed the following:
- 1) For Contractor, for any Work actually performed by Contractor's own forces, 16% of the cost.
 - 2) For each Subcontractor (including lower tier subcontractors), for any Work actually performed by its own forces, 16% of the cost.
 - 3) For Contractor, for any Work performed by its Subcontractor(s), 6% of the amount due each Subcontractor.
 - 4) For each Subcontractor, for any Work performed by its Subcontractor(s) of any lower tier, 5% of the amount due the sub-Subcontractor.
- e. Allowance for Profit:
- 1) For Contractor or Subcontractor of any tier for work performed by their forces, 5% of the cost developed in accordance with subsections a, b & c above.
 - 2) For Contractor or Subcontractor of any tier for work performed by a subcontractor of a lower tier, 5% of the Subcontractor cost.
- f. Insurance or Bond Premium: The costs of any change or additional premium of Contractor's liability insurance and public works bond arising directly from the changed Work. The costs of any change in insurance or bond premium shall be added after overhead and profit are calculated.
- g. Washington State sales tax as applicable.
- B. Change Order Pricing - Unit Prices
1. Work on a unit-price basis as stated in the Specifications and at the price submitted in the Bid Form or as subsequently modified.
 - a. Unit prices shall include reimbursement for all direct and indirect costs of the Work, including overhead and profit, and bond, insurance costs and retail sales tax; and
 - b. Quantities must be supported by field measurement verified by Owner.

7.3 CHANGE IN THE CONTRACT TIME

- A. The Contract Time shall only be changed by a Change Order. Contractor shall immediately notify Owner, and shall include any request for a change in the Contract Time in its Change Order proposal.

GENERAL CONDITIONS

- B. If the time of Contractor's performance is changed due to an act of Force Majeure, Contractor shall request for an equitable adjustment in the Contract Time in writing within 24-hours of the occurrence.

PART 8 - CLAIMS AND DISPUTE RESOLUTION

8.1 CLAIMS PROCEDURE

- A. Claim is Contractor's remedy: If the parties fail to reach agreement on the terms of any Change Order for Owner-directed Work as provided in Part 7.1, or on the resolution of any request for an equitable adjustment in the Contract Sum as provided in Part 7.2 or the Contract Time as provided in Part 7.3, Contractor's only remedy shall be to file a Claim with Owner as provided in this section.
- B. Claim filing deadline for Contractor: Contractor shall file its Claim within 30 Days from Owner's final offer made in accordance with Part 7.1E, or by the date of Final Acceptance, whichever occurs first.
- C. Claim must cover all costs and be documented: The Claim shall be deemed to cover all changes in cost and time (including direct, indirect, impact, and consequential) to which Contractor may be entitled. It shall be fully substantiated and documented. At a minimum, the Claim shall contain the following information:
 - 1. Factual statement of Claim: A detailed factual statement of the Claim for additional compensation and time, if any, providing all necessary dates, locations, and items of Work affected by the Claim;
 - 2. Dates: The date on which facts arose which gave rise to the Claim;
 - 3. Owner and A/E employees knowledgeable about Claim: The name of each employee of Owner or A/E knowledgeable about the Claim;
 - 4. Support from Contract Documents: The specific provisions of the Contract Documents which support the Claim;
 - 5. Identification of other supporting information: The identification of any documents and the substance of any oral communications that support the Claim;
 - 6. Copies of supporting documentation: Copies of any identified documents, other than the Contract Documents, that support the Claim;
 - 7. Details on Claim for Contract Time: If an adjustment in the Contract Time is sought: the specific days and dates for which it is sought; the specific reasons Contractor believes an extension in the Contract Time should be granted; and Contractor's analysis of its Progress Schedule to demonstrate the reason for the extension in Contract Time;
 - 8. Details on Claim for adjustment of Contract Sum: If an adjustment in the Contract Sum is sought, the exact amount sought and a breakdown of that amount into the categories set forth in, and in the detail as required by Part 7.2; and
 - 9. Statement certifying Claim: A statement certifying, under penalty of perjury, that the Claim is made in good faith, that the supporting cost and pricing data are true and accurate to the best of Contractor's knowledge and belief, that the Claim is fully supported by the accompanying data, and that the amount requested accurately reflects the adjustment in the Contract Sum or Contract Time for which Contractor believes Owner is liable.
- D. Owner's response to Claim filed: After Contractor has submitted a fully documented Claim that complies with all applicable provisions of Parts 7 and 8, Owner shall respond, in writing, to Contractor with a decision within 30 Days from the date the Claim is received.
- E. Owner's review of Claim and finality of decision: To assist in the review of Contractor's Claim, Owner may visit the Project site, or request additional information, in order to fully evaluate the issues raised by the Claim. Contractor shall proceed with performance of the Work pending final resolution of any Claim. Owner's written decision as set forth above shall be final and conclusive as to all matters set forth in the Claim, unless Contractor follows the procedure set forth in Part 8.2.
- F. Waiver of Contractor rights for failure to comply with this Section: Any Claim of the Contractor against the Owner for damages, additional compensation, or additional time, shall be conclusively deemed to have been waived by the Contractor unless timely made in accordance with the requirements of this Section.

GENERAL CONDITIONS

8.2 ARBITRATION

- A. Timing of Contractor's demand for arbitration: If Contractor disagrees with Owner's decision rendered in accordance with Part 8.1D, Contractor shall provide Owner with a written demand for arbitration. No demand for arbitration of any such Claim shall be made later than 30 Days after the date of Owner's decision on such Claim; failure to demand arbitration within said 30 Day period shall result in Owner's decision being final and binding upon Contractor and its Subcontractors.
- B. Filing of Notice for arbitration: Notice of the demand for arbitration shall be filed with the American Arbitration Association (AAA), with a copy provided to Owner. The parties shall negotiate or mediate under the Voluntary Construction Mediation Rules of the AAA, or mutually acceptable service, before seeking arbitration in accordance with the Construction Industry Arbitration Rules of AAA as follows:
 - 1. Claims less than \$30,000: Disputes involving \$30,000 or less shall be conducted in accordance with the Northwest Region Expedited Commercial Arbitration Rules; or
 - 2. Claims greater than \$30,000: Disputes over \$30,000 shall be conducted in accordance with the Construction Industry Arbitration Rules of the AAA, unless the parties agree to use the expedited rules.
- C. Arbitration is forum for resolving Claims: All Claims arising out of the Work shall be resolved by arbitration. The judgment upon the arbitration award may be entered, or review of the award may occur, in the superior court having jurisdiction thereof. No independent legal action relating to or arising from the Work shall be maintained.
- D. Owner may combine Claims into same arbitration: Claims between Owner and Contractor, Contractor and its Subcontractors, Contractor and A/E, and Owner and A/E shall, upon demand by Owner, be submitted in the same arbitration or mediation.
- E. Settlement outside of arbitration to be documented in Change Order: If the parties resolve the Claim prior to arbitration judgment, the terms of the resolution shall be incorporated in a Change Order. The Change Order shall constitute full payment and final settlement of the Claim, including all claims for time and for direct, indirect, or consequential costs, including costs of delays, inconvenience, disruption of schedule, or loss of efficiency or productivity.

8.3 CLAIMS AUDITS

- A. Owner may audit Claims: All Claims filed against Owner shall be subject to audit at any time following the filing of the Claim. Failure of Contractor, or Subcontractors of any tier, to maintain and retain sufficient records to allow Owner to verify all or a portion of the Claim or to permit Owner access to the books and records of Contractor, or Subcontractors of any tier, shall constitute a waiver of the Claim and shall bar any recovery.
- B. Contractor to make documents available: In support of Owner audit of any Claim, Contractor shall, upon request, promptly make available to Owner the following documents:
 - 1. Daily time sheets and supervisor's daily reports;
 - 2. Collective bargaining agreements;
 - 3. Insurance, welfare, and benefits records;
 - 4. Payroll registers;
 - 5. Earnings records;
 - 6. Payroll tax forms;
 - 7. Material invoices, requisitions, and delivery confirmations;
 - 8. Material cost distribution worksheet;
 - 9. Equipment records (list of company equipment, rates, etc.);
 - 10. Vendors', rental agencies', Subcontractors', and agents' invoices;
 - 11. Contracts between Contractor and each of its Subcontractors, and all lower-tier Subcontractor contracts and supplier contracts;
 - 12. Subcontractors' and agents' payment certificates;
 - 13. Cancelled checks (payroll and vendors);
 - 14. Job cost report, including monthly totals;
 - 15. Job payroll ledger;
 - 16. Planned resource loading schedules and summaries;
 - 17. General ledger;
 - 18. Cash disbursements journal;

GENERAL CONDITIONS

19. Financial statements for all years reflecting the operations on the Work. In addition, the Owner may require, if it deems it appropriate, additional financial statements for 3 years preceding execution of the Work;
 20. Depreciation records on all company equipment whether these records are maintained by the company involved, its accountant, or others;
 21. If a source other than depreciation records is used to develop costs for Contractor's internal purposes in establishing the actual cost of owning and operating equipment, all such other source documents;
 22. All nonprivileged documents which relate to each and every Claim together with all documents which support the amount of any adjustment in Contract Sum or Contract Time sought by each Claim;
 23. Work sheets or software used to prepare the Claim establishing the cost components for items of the Claim including but not limited to labor, benefits and insurance, materials, equipment, Subcontractors, all documents which establish the time periods, individuals involved, the hours for the individuals, and the rates for the individuals; and
 24. Work sheets, software, and all other documents used by Contractor to prepare its bid.
- C. Contractor to provide facilities for audit and shall cooperate: The audit may be performed by employees of Owner or a representative of Owner. Contractor, and its Subcontractors, shall provide adequate facilities acceptable to Owner, for the audit during normal business hours. Contractor, and all Subcontractors, shall make a good faith effort to cooperate with Owner's auditors.

PART 9 - TERMINATION OF THE WORK

9.1 TERMINATION BY OWNER FOR CAUSE

- A. 7 Day Notice to Terminate for Cause: Owner may, upon Notice to Contractor and to its surety, terminate (without prejudice to any right or remedy of Owner) the Work, or any part of it, for cause upon the occurrence of any one or more of the following events:
1. Contractor fails to prosecute Work: Contractor fails to prosecute the Work or any portion thereof with sufficient diligence to ensure Substantial Completion of the Work within the Contract Time;
 2. Contractor bankrupt: Contractor is adjudged bankrupt, makes a general assignment for the benefit of its creditors, or a receiver is appointed on account of its insolvency;
 3. Contractor fails to correct Work: Contractor fails in a material way to replace or correct Work not in conformance with the Contract Documents;
 4. Contractor fails to supply workers or materials: Contractor repeatedly fails to supply skilled workers or proper materials or equipment;
 5. Contractor failure to pay Subcontractors or labor: Contractor repeatedly fails to make prompt payment due to Subcontractors or for labor;
 6. Contractor violates laws: Contractor materially disregards or fails to comply with laws, ordinances, rules, regulations, or orders of any public authority having jurisdiction; or
 7. Contractor in material breach of Contract: Contractor is otherwise in material breach of any provision of the Contract Documents.
- B. Owner's actions upon termination: Upon termination, Owner may at its option:
1. Take possession of Project site: Take possession of the Project site and take possession of or use all materials, equipment, tools, and construction equipment and machinery thereon owned by Contractor to maintain the orderly progress of, and to finish, the Work;
 2. Accept assignment of Subcontracts: Accept assignment of subcontracts pursuant to Part 5.20; and
 3. Finish the Work: Finish the Work by whatever other reasonable method it deems expedient.
- C. Surety's role: Owner's rights and duties upon termination are subject to the prior rights and duties of the surety, if any, obligated under any bond provided in accordance with the Contract Documents.
- D. Contractor's required actions: When Owner terminates the Work in accordance with this section, Contractor shall take the actions set forth in Part 9.2B, and shall not be entitled to receive further payment until the Work is accepted.
- E. Contractor to pay for unfinished Work: If the unpaid balance of the Contract Sum exceeds the cost of finishing the Work, including compensation for A/E's services and expenses made necessary thereby and any other extra costs or damages incurred by Owner in completing the Work, or as a result of Contractor's actions, such excess

GENERAL CONDITIONS

shall be paid to Contractor. If such costs exceed the unpaid balance, Contractor shall pay the difference to Owner. These obligations for payment shall survive termination.

- F. Contractor and Surety still responsible for Work performed: Termination of the Work in accordance with this section shall not relieve Contractor or its surety of any responsibilities for Work performed.
- G. Conversion of "Termination for Cause" to "Termination for Convenience": If Owner terminates Contractor for cause and it is later determined that none of the circumstances set forth in Part 9.1A exist, then such termination shall be deemed a termination for convenience pursuant to Part 9.2.

9.2 TERMINATION BY OWNER FOR CONVENIENCE

- A. Owner Notice of Termination for Convenience: Owner may, upon Notice, terminate (without prejudice to any right or remedy of Owner) the Work, or any part of it, for the convenience of Owner.
- B. Contractor response to termination Notice: Unless Owner directs otherwise, after receipt of a Notice of termination for either cause or convenience, Contractor shall promptly:
 - 1. Cease Work: Stop performing Work on the date and as specified in the notice of termination;
 - 2. No further orders or Subcontracts: Place no further orders or subcontracts for materials, equipment, services or facilities, except as may be necessary for completion of such portion of the Work as is not terminated;
 - 3. Cancel orders and Subcontracts: Cancel all orders and subcontracts, upon terms acceptable to Owner, to the extent that they relate to the performance of Work terminated;
 - 4. Assign orders and Subcontracts to Owner: Assign to Owner all of the right, title, and interest of Contractor in all orders and subcontracts;
 - 5. Take action to protect the Work: Take such action as may be necessary or as directed by Owner to preserve and protect the Work, Project site, and any other property related to this Project in the possession of Contractor in which Owner has an interest; and
 - 6. Continue performance not terminated: Continue performance only to the extent not terminated
- C. Terms of adjustment in Contract Sum if Contract terminated: If Owner terminates the Work or any portion thereof for convenience, Contractor shall be entitled to make a request for an equitable adjustment for its reasonable direct costs incurred prior to the effective date of the termination, plus reasonable allowance for overhead and profit on Work performed prior to termination, plus the reasonable administrative costs of the termination, but shall not be entitled to any other costs or damages, whatsoever, provided however, the total sum payable upon termination shall not exceed the Contract Sum reduced by prior payments. Contractor shall be required to make its request in accordance with the provisions of Part 7.
- D. Owner to determine whether to adjust Contract Time: If Owner terminates the Work or any portion thereof for convenience, the Contract Time shall be adjusted as determined by Owner.

PART 10 - MISCELLANEOUS PROVISIONS

10.1 GOVERNING LAW

- A. Applicable law and venue: The Contract Documents and the rights of the parties herein shall be governed by the laws of the state of Washington. Venue shall be in the county in which Owner's principal place of business is located, unless otherwise specified.

10.2 SUCCESSORS AND ASSIGNS

- A. Bound to successors; Assignment of Contract: Owner and Contractor respectively bind themselves, their partners, successors, assigns, and legal representatives to the other party hereto and to partners, successors, assigns, and legal representatives of such other party in respect to covenants, agreements, and obligations contained in the Contract Documents. Neither party shall assign the Work without written consent of the other, except that Contractor may assign the Work for security purposes, to a bank or lending institution authorized to do business in the state of Washington. If either party attempts to make such an assignment without such consent, that party shall nevertheless remain legally responsible for all obligations set forth in the Contract Documents.

GENERAL CONDITIONS

10.3 MEANING OF WORDS

- A. Meaning of words used in Specifications: Unless otherwise stated in the Contract Documents, words which have well-known technical or construction industry meanings are used in the Contract Documents in accordance with such recognized meanings. Reference to standard specifications, manuals, or codes of any technical society, organization, or association, or to the code of any governmental authority, whether such reference be specific or by implication, shall be to the latest standard specification, manual, or code in effect on the date for submission of bids, except as may be otherwise specifically stated. Wherever in these Drawings and Specifications an article, device, or piece of equipment is referred to in the singular manner, such reference shall apply to as many such articles as are shown on the drawings, or required to complete the installation.

10.4 RIGHTS AND REMEDIES

- A. No waiver of rights: No action or failure to act by Owner or A/E shall constitute a waiver of a right or duty afforded them under the Contract Documents, nor shall action or failure to act constitute approval or an acquiescence in a breach therein, except as may be specifically agreed in writing. Waiver of any provision of the Contract Documents shall not be construed to be a modification of the such provisions, unless the Contract Documents are modified pursuant to the Clause entitled "Contract Modifications" herein.
- B. If any provision of the Contract Documents is or becomes void or unenforceable by operation of law, the remaining provisions shall be valid and enforceable.

10.5 TIME COMPUTATIONS

- A. Computing time: When computing any period of time, the day of the event from which the period of time begins shall not be counted. The last day is counted unless it falls on a weekend or legal holiday, in which event the period runs until the end of the next day that is not a weekend or holiday. When the period of time allowed is less than 7 days, intermediate Saturdays, Sundays, and legal holidays are excluded from the computation.

10.6 RECORDS RETENTION AND REPORTING

- A. Record keeping: The Contractor and all Subcontractors shall maintain accounts and records in accordance with State Auditor's procedures, including personnel, property, financial and programmatic records which sufficiently and properly reflect all direct and indirect costs of any nature expended and services performed in the performance of the Contract Documents and other such records as may be deemed necessary by the Owner to ensure proper accounting for all funds contributed by the Owner to the performance of the Contract Documents and compliance with this Contract.
- B. Six year records retention period: Contractor and its Subcontractors shall maintain these records for a period of not less than 6 years after the date of Final Acceptance.

10.7 THIRD-PARTY AGREEMENTS

- A. No third party relationships created: The Contract Documents shall not be construed to create a contractual relationship of any kind between: A/E and Contractor; Owner and any Subcontractor; or any persons other than Owner and Contractor. Contractor is an independent contractor with respect to the Work. Nothing in the Contract Documents shall be considered to create a relationship of employer and employee between the parties hereto. Neither the Contractor nor any employee of the Contractor shall be entitled to any benefits accorded Owner employees by virtue of the services provided. The Owner shall not be responsible for withholding or otherwise deducting federal income tax or social security or contributing to the State Industrial Insurance Program, or otherwise assuming the duties of an employer with respect to the Contractor, or any employees of the Contractor.

10.8 ANTITRUST ASSIGNMENT

- A. Contractor assigns overcharge amounts to Owner: Owner and Contractor recognize that in actual economic practice, overcharges resulting from antitrust violations are in fact usually borne by the purchaser. Therefore, Contractor hereby assigns to Owner any and all claims for such overcharges as to goods, materials, and equipment purchased in connection with the Work performed in accordance with the Contract Documents, except as to overcharges which result from antitrust violations commencing after the Contract Sum is established and

GENERAL CONDITIONS

which are not passed on to Owner under a Change Order. Contractor shall put a similar clause in its Subcontracts, and require a similar clause in its sub- Subcontracts, such that all claims for such overcharges on the Work are passed to Owner by Contractor.

10.9 AUDITS AND INSPECTIONS

- A. The records and documents with respect to all matters covered by the Contract Documents shall be subject at all times to inspection, review or audit by the Owner or any other government agency so authorized by law during the performance of the Work. The Owner shall have the right to an annual audit of the Contractor's financial statement and condition.

10.10 ORGANIZATION CONFLICTS OF INTEREST

- A. The Contractor warrants that, to the best of its knowledge and belief and except as otherwise disclosed, it does not have any organizational conflict of interest which is defined as a situation in which the nature of work under the Contract Documents and the Contractor's organizational, financial, contractual or other interests are such that:
 - 1. Award of the Work may result in an unfair competitive advantage; or
 - 2. The Contractor's objectivity in performing the Work may be impaired.
- B. The Contractor agrees that if after award it discovers an organizational conflict of interest with respect to performance of the Work, it shall make an immediate and full disclosure in writing to the Contracting Officer, which shall include a description of the action the Contractor has taken or intends to take to eliminate or neutralize the conflict. The Owner may, however, terminate the Work if it deems the action to be in the best interest of the Owner.
- C. In the event the Contractor was aware of an organizational conflict of interest before the award of this Contract and intentionally did not disclose the conflict to the Contracting Officer, the Owner may terminate the Work for cause.
- D. The provisions of this Section 10.11 shall be included in all subcontracts and consulting agreements wherein the work to be performed is similar to the services provided by the Contractor. The Contractor shall include in such subcontracts and consulting agreements any necessary provisions to eliminate or neutralize conflicts of interest.

10.11 INTERESTS OF MEMBERS OF CONGRESS

- A. No member of or delegate to the Congress of the United States of America shall be admitted to any share or part of the Contract Documents or to any benefit to arise therefrom, but this provision shall not be construed to extend to the Contract Documents if made with a corporation for its general benefit.

10.12 HEADINGS AND CAPTIONS

- A. Headings for convenience only: All headings and captions used in these General Conditions are only for convenience of reference, and shall not be used in any way in connection with the meaning, effect, interpretation, construction, or enforcement of the General Conditions, and do not define the limit or describe the scope or intent of any provision of these General Conditions.

BID FORM

PROJECT NAME AND LOCATION:

**Asphalt Replacement
Woodland North Apartments**

Contract Number: TC2400131

BID FORM

The undersigned, Legal Name of Bidder: _____

on this date: _____, 2024, having familiarized him/herself with the contract documents, site conditions, and has field verified all measurements contained in the project manual as prepared by the Owner, hereby proposes to furnish labor, materials and necessary equipment – all including, but not limited to, demolition, disposal, new installation and the required applicable taxes and fees to complete the work for the following bid amounts:

BASE BID _____ (\$ _____)

RETAIL SALES TAX _____ (\$ _____)

TOTAL BASE BID _____ (\$ _____)

UNIT PRICES See Specification Section 01100, 1.6D – Unit Prices (Unit Prices should not include sales tax)

Unit Price No. 1 _____ (\$ _____)
Asphalt

Unit Price No. 2 _____ (\$ _____)
Extruded Curb

Unit Price No. 3 _____ (\$ _____)
Curb & Gutter

Unit Price No. 4 _____ (\$ _____)
Speed Bumps

Unit Price No. 5 _____ (\$ _____)
Wheel Stops

ADDENDA _____

Acknowledge receipt of any addenda by inserting the number(s) above

BID FORM

In submitting this bid, it is understood that the right is reserved by the Owner to reject any and all bids. The undersigned hereby agrees that this proposal shall be a valid and firm offer for a period of Sixty (60) calendar days from the date of Bid Opening.

Bidder agrees that Work will be substantially complete and ready for final payment in accordance with the Contract Documents on or before the date, within the number of calendar days indicated.

I certify (or declare) under penalty of perjury under the laws of the State of Washington that the foregoing is true and correct.

Signature of Bidder

Print Your Name

Submitted on _____ day of _____ 2024

City

State

BIDDER INFORMATION

BIDDER INFORMATION

Name of Bidder (Company): _____

Address: _____

Contact Name: _____

Phone Number: _____ Email Address: _____

Business Type: General Contractor () Other () (Please specify): _____

Bidder is a(n): Individual Partnership Joint Venture Incorporated in the state of _____

List business names & associated UBI # used by Bidder during the past 5 years if different than above:

Bidder has been in business continuously from: _____
Month, Year

Business License #: _____ Federal ID #: _____

Current UBI #: _____ Dept. of L&I Worker's Comp. Acct. #: _____

Bidder has experience in work "Similar in Scope and Complexity" comparable to that required for this Project:

As a prime contractor for _____ years. As a subcontractor for _____ years.

OWNER(S) OF COMPANY (List all owners):	OWNER'S SOCIAL SECURITY NUMBER (only required if sole proprietorship):

No. of regular full-time employees other than owner(s): _____

Indicate clearly the kind of work your company will actually perform in this project:

Approximate % of work your company will actually perform: _____

List the supervisory personnel to be employed by the Bidder and available for, and intended to, work on this project:

<u>Name</u>	<u>Title</u>	<u>How Long With Bidder</u>

BIDDER INFORMATION

SUBCONTRACTORS

Do you intend to use Subcontractor(s) in this project? Yes No (If yes, you must show the name of the subcontractors. Attach additional pages as necessary.)

Subcontractors Name	Subcontractor's UBI#	Phone Number	Trade	Years in Business
1.				
2.				
3.				
4.				
5.				

BIDDER'S EXPERIENCE

Projects successfully supervised and completed by your company for work of similar scope and value as specified in bid documents in the last 5 years. Attach additional pages as necessary.

Name of Project	Completion Date	Duration (Months)	Nature of Work	Amount of Contract
1.				
2.				
3.				
4.				
5.				

Owner's Name (of project listed above)	Project Address	Contact Person	Phone Number
1.			
2.			
3.			
4.			
5.			

Has Bidder ever been found guilty of violating any State or Federal employment laws? No Yes

If yes, give details & attach additional pages as necessary: _____

Has Bidder ever filed for protection under any provision of the federal bankruptcy laws or state insolvency laws?

No Yes If yes, give details & attach additional pages as necessary: _____

BIDDER INFORMATION

Has any lien, claim and/or adverse legal action related to construction been rendered against Bidder in the past five years? (i.e., open claims, lawsuits, warrants, judgements including but not limited to those that would show on the L&I website) No Yes If yes, give details & attach additional pages as necessary: _____

Has Bidder or any of its employees filed any claims with Washington State Worker's Compensation or other insurance company for accidents resulting in fatal injury or dismemberment in the past 5 years? No Yes
If yes, please state:

<u>Date</u>	<u>Type of Injury</u>	<u>Agency Receiving Claim</u>
_____	_____	_____
_____	_____	_____

Bidders current Experience Modification Rate (EMR): _____

(If Bidder is self-insured, attach proof of EMR stated, showing complete worksheet calculations)

The bidder hereby certifies that the information contained in this Bidder's Information is accurate, complete and current.

BY: _____ NAME: _____
(signature) (print)

TITLE: _____ DATE: _____

Sample Wage Rate Schedule Applicable to Woodland North Renovations

<u>County</u>	<u>Trade</u>	<u>Job Classification</u>	<u>Wage</u>
King	Traffic Control Stripers	Journey Level	\$31.52
		Journey Level	\$89.54
King	Truck Drivers	Asphalt Mix Over 16 Yards	\$74.95
King	Truck Drivers	Asphalt Mix To 16 Yards	\$74.02
King	Truck Drivers	Dump Truck & Trailer	\$74.02
King	Truck Drivers	Dump Truck (W. WA-Joint Council 28)	\$74.95
King	Truck Drivers	Other Trucks (W. WA-Joint Council 28)	\$74.95
King	Flaggers	Journey Level	\$50.07
King	Power Equipment operator-rotogrinder	Various	\$78.65-\$86.48
King	Laborers	Various	various

Woodland North LLLP
600 Andover Park West
Seattle, WA 98188

Agreement to Pay Prevailing Wages

Contractor certifies that all workers, laborers, or mechanics employed in the performance of any part of the Work shall be paid the prevailing rate of wages to in accordance with the requirements of the Owner and the Wage Rate Schedule.
Form must be filed with the Owner prior to commencement of Work.

Company Details

Company Name:	
Address:	
Contractor Registration No.	
WA UBI Number	
Phone Number	
Industrial Insurance Account ID	
Email Address	
Filed By	

Prime Contractor

Company Name	
Contractor Registration No.	
WA UBI Number	
Phone Number	

Project Information

Contract Number	TC2400131
Project Name	Woodland North
Contract Amount	
Project Site Address	3611 NE 155th Street Lake Forest Park WA 98155

Intent Details

Expected project start date: (MM-DD-YYYY)	
Does your company intend to hire ANY subcontractors?	
Will your company have employees perform work on this project?	
Do you intend to use any apprentices? (Apprentices are considered employees.)	

Journey Level Wages

County	Trade	Wage	Fringe	# Workers

Apprentice Level Wages

Step	Trade	Wage %	Wage	Fringe	# Workers

Signature: _____

Print
Name: _____

Date: _____

Woodland North LLLP
600 Andover Park West
Seattle, WA 98188

Affidavit of Wages Paid

Contractor certifies that all workers, laborers, or mechanics employed in the performance of any part of the Work have been paid the prevailing rate of wages to in accordance with the requirements of the Owner and the Wage Rate Schedule.
Form must be filed with the Owner prior to Final Acceptance.

Company Details

Company Name:	
Address:	
Contractor Registration No.	
WA UBI Number	
Phone Number	
Industrial Insurance Account ID	
Email Address	
Filed By	

Project Information

Contract Number	TC2400131
Project Name	Woodland North Apartments Asphalt
Project Site Address	3611 NE 155th St. Lake Forest Park, WA 98198
Prime Contractor Name	
Prime Contractor Registration No.	
Prime Contractor Phone Number	
Dollar Amount of Your Contract:	
Job Start Date: MM-DD-YYYY	
Date Work Completed: MM-DD-YYYY	

Project Completion

Did your company hire any subcontractors?	
Did your company have employees perform work on this project?	
Did you use any apprentices on this job? (Apprentices are considered employees.)	

Project Subcontractors

Company Name	Primary Contact	Phone	UBI

Journey Level Wages

County	Trade	Wage	Fringe	# of Workers

Apprentice Level Wages

County	Trade	Wage %	Wage	Fringe	# of Workers

Signature: _____

Print Name: _____

Date: _____

CONTRACT FORM

This Contract is entered into by and between the Woodland North LLLP, hereinafter referred to as the "Owner" whose principal office is located at 600 Andover Park West, Seattle, WA 98188 and [Name of Contractor], referred to as the "Contractor", whose principal office is located at [Contractor's Address].

IN CONSIDERATION OF the mutual benefits and conditions hereinafter contained, the parties hereto agree as follows:

1.1 Contract Documents

A. The provisions set forth in the Contract Documents are hereby incorporated into and made part of the Contract. Contractor acknowledges receipt and review of all Contract Documents applicable to performance of the work. The Contract shall consist of the following component parts:

1. This Instrument
2. Addenda
3. Specifications
4. Plans
5. Bid Form
6. Pre-Bid Agenda
7. General Conditions
8. Instructions to Bidders
9. Wage Rates
10. Agreement to Pay Prevailing Wage
11. Performance and Payment Bond

1.2 Scope of Services to be Performed by the Contractor: The Contractor shall provide all labor, materials, tools, equipment, transportation, supplies, and incidentals required to complete the work in accordance with the Contract Documents for:

Project: Woodland North Asphalt Replacement

Contract No.: TC2400131

1.3 Compensation:

Base Bid - \$[\$\$\$]

[##]% Washington State Retail Sales Tax - \$[\$\$\$]

The total amount of the Contract shall be [Total Base Bid] dollars and [Total Base Bid] cents (\$[\$\$\$]) subject to additions and deductions provided therein.

1.4 Duration of Contract: The Contractor shall commence work after receipt of Notice to Proceed, follow the schedule specified in the contract documents, and all work must be completed within thirty (30) consecutive calendar days, as indicated in the Specifications, from the date of the Notice to Proceed unless sooner terminated pursuant to the General Conditions. Upon expiration of the original Contract term, the Contract, at the Owner's sole discretion, may be extended for a period determined by the Owner.

1.5 Liquidated Damages: Timely performance and completion of the Work is essential to Owner and time limits stated in the Contract Documents are of the essence. If Completion of the Work does not occur within the Contract Time, the Contractor agrees that Liquidated Damages in the amounts stated in the Bid Documents will be assessed for each calendar day that the Contractor exceeds the time for completion.

The individuals signing this Contract warrant and represent for themselves and for their respective organizations that they are duly authorized to sign this Contract and that upon such signing their respective organizations are bound thereby.

DATED this _____ day of _____, 2024

Contractor

Owner

President/Owner

Select a Signer.
Select Title., KCHA
Its General Partner

CERTIFICATE OF INSURANCE

DATE(MM/DD/YY)

Issue Date

PRODUCER Vendor's Insurance Agent Street Address City, State, Zip Phone Number	THIS CERTIFICATE IS ISSUED AS A MATTER OF INFORMATION ONLY AND CONFERS NO RIGHTS UPON THE CERTIFICATE HOLDER. THIS CERTIFICATE DOES NOT AMEND, EXTEND OR ALTER THE COVERAGE AFFORDED BY THE POLICIES BELOW.
---	--

COMPANIES AFFORDING COVERAGE	
COMPANY A	ABC Insurance Company

INSURED Vendor Name Street Address City, State, Zip	<table border="1" style="width: 100%; border-collapse: collapse;"> <tr> <td style="width: 15%; text-align: center;">COMPANY B</td> <td>DEF Insurance Company</td> </tr> <tr> <td style="width: 15%; text-align: center;">COMPANY C</td> <td>GHI Insurance Company</td> </tr> <tr> <td style="width: 15%; text-align: center;">COMPANY D</td> <td></td> </tr> </table>	COMPANY B	DEF Insurance Company	COMPANY C	GHI Insurance Company	COMPANY D	
COMPANY B	DEF Insurance Company						
COMPANY C	GHI Insurance Company						
COMPANY D							

COVERAGES
 THIS IS TO CERTIFY THAT THE POLICIES OF INSURANCE LISTED BELOW HAVE BEEN ISSUED TO THE INSURED NAMED ABOVE FOR THE POLICY PERIOD INDICATED. NOTWITHSTANDING ANY REQUIREMENT, TERM OR CONDITION OF ANY CONTRACT OR OTHER DOCUMENT WITH RESPECT TO WHICH THIS CERTIFICATE MAY BE ISSUED OR MAY PERTAIN, THE INSURANCE AFFORDED BY THE POLICIES DESCRIBED HEREIN IS SUBJECT TO ALL THE TERMS, EXCLUSIONS AND CONDITIONS OF SUCH POLICIES. LIMITS SHOWN MAY HAVE BEEN REDUCED BY PAID CLAIMS.

CO LTR	TYPE OF INSURANCE	POLICY NUMBER	POLICY EFFECTIVE DATE (MM/DD/YY)	POLICY EXPIRATION DATE (MM/DD/YY)	LIMITS	
A	GENERAL LIABILITY	XXX123	01/01/00	01/01/01	GENERAL AGGREGATE	2,000,000
	<input checked="" type="checkbox"/> COMMERCIAL GENERAL LIABILITY				PRODUCTS-COMP/OP AGG	1,000,000
	<input type="checkbox"/> CLAIMS MADE <input checked="" type="checkbox"/> OCCUR				PERSONAL & ADV INJURY	1,000,000
	<input type="checkbox"/> OWNER'S & CONTRACTOR'S PROT				EACH OCCURRENCE	1,000,000
					FIRE DAMAGE (Any one fire)	50,000
					MED EXP (Any one person)	5,000
B	AUTOMOBILE LIABILITY	XXX456	01/01/00	01/01/01	COMBINED SINGLE LIMIT	1,000,000
	<input checked="" type="checkbox"/> ANY AUTO				BODILY INJURY (Per person)	
	<input type="checkbox"/> ALL OWNED AUTOS				BODILY INJURY (Per accident)	
	<input checked="" type="checkbox"/> HIRED AUTOS				PROPERTY DAMAGE	
<input type="checkbox"/> SCHEDULED AUTOS						
<input type="checkbox"/> NON-OWNED AUTOS						
	GARAGE LIABILITY				AUTO ONLY-EA ACCIDENT	
	<input type="checkbox"/> ANY AUTO				OTHER THAN AUTO ONLY:	
					EACH ACCIDENT	
					AGGREGATE	
	EXCESS LIABILITY				EACH OCCURRENCE	
	<input type="checkbox"/> UMBRELLA FORM				AGGREGATE	
	<input type="checkbox"/> OTHER THAN UMBRELLA FORM					
C	WORKERS' COMPENSATION AND EMPLOYER'S LIABILITY	XXX789	01/01/00	01/01/01	<input checked="" type="checkbox"/> STATUTORY LIMITS	
	<input type="checkbox"/> THE PROPRIETOR/PARTNERS/EXECUTIVE OFFICERS ARE:				EACH ACCIDENT	1,000,000
	<input type="checkbox"/> INCL				DISEASE-POLICY LIMIT	1,000,000
	<input type="checkbox"/> EXCL				DISEASE-EACH EMPLOYEE	1,000,000
	OTHER					

DESCRIPTION OF OPERATIONS/LOCATIONS/VEHICLES/SPECIAL ITEMS
 Allied Residential; King County Housing Authority; Woodland North LLLP; BF Garden Affordable Housing Fund V, LLC & BCCC, Inv. c/o D&M Insurance Solutions are named as additional insureds with respect to above general liability and auto coverages.
 Re: Insured's work/services provided at Woodland North Apartments, 3611 NE 155th St, Lake Forest Park, WA 98155 Contract # TC2400131

CERTIFICATE HOLDER Allied Residential; King County Housing Authority; Woodland North LLLP; BF Garden Affordable Housing Fund V, LLC & BCCC, Inv. c/o D&M Insurance Solutions 600 Andover Park West Seattle, WA 98188-3326	CANCELLATION SHOULD ANY OF THE ABOVE DESCRIBED POLICIES BE CANCELED BEFORE THE EXPIRATION DATE THEREOF, THE ISSUING COMPANY WILL ENDEAVOR TO MAIL 30 DAYS WRITTEN NOTICE TO THE CERTIFICATE HOLDER NAMED TO THE LEFT, BUT FAILURE TO MAIL SUCH NOTICE SHALL IMPOSE NO OBLIGATION OR LIABILITY OF ANY KIND UPON THE COMPANY, ITS AGENTS OR REPRESENTATIVES. AUTHORIZED REPRESENTATIVE Signature of Insured's Agent
ACORD 25-S (3/93)	ACORD CORPORATION 1993

PROVIDE

**GENERAL LIABILITY
ENDORSEMENT**

and

**AUTO LIABILITY
ENDORSEMENT**